

KA1771

JAYCAR
ELECTRONICS

AUDIO POWER AMPLIFIER KIT

**320 WRMS/4OHMS
200 WRMS/8OHMS**

What a monster! This superb power amplifier can be used as a subwoofer, musical instrument amplifier, or high power hi-fi amplifier. It uses the latest in MOSFET technology, and delivers excellent noise and distortion figures (S/N: >95dB, THD: 0.005% at 300W!). This is same module that is used in our KA1770 Subwoofer Amplifier Kit. The amp requires +/-75VDC supply rails, use our MT2144 toroidal transformer, ZR1324 bridge rectifier and two RU6710 8,000 uF filter caps. Heatsink also required, use HH8554. Kit is supplied with PCB, heatsink mounting bracket, plus all electronic components.

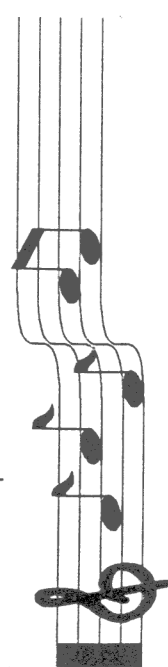
Degree of simplicity ✓✓

by ROB EVANS

With the strong interest from readers in subwoofer systems over recent years, it's become increasingly clear that a dedicated *subwoofer* amplifier project is long overdue from the *Electronics Australia* lab. To some degree this need has been pushed along by the rising popularity of subwoofer based home 'theatre' sound systems — plus, of course, the number of subwoofer enclosures we've presented as construction projects in past issues.

As it happens, the last project of this type was described way back in the July 1982 issue of EA, and was a relatively simple affair with a power rating of around 100 watts and an integrated low-pass filter section to tailor the response of the incoming signals, as opposed to a full active crossover stage. While this worked quite well in practice, the subsequent 'Active crossover for subwoofers' unit published in the more recent September 1994 issue clearly showed us the advantages of using a full two-way active crossover with subwoofers.

To put it briefly, when using the latter unit the system's low end response is much smoother, due to the controlled (and matched in phase) roll-off slopes applied to both the main and subwoofer speakers, and it's much easier to acoustically integrate the two speaker systems by selecting the optimum crossover frequency with the front panel control. We found the improvement to be very impressive indeed, and as you've no doubt guessed, the same design has been incorporated in our new subwoofer amplifier.

In the process of including the crossover circuit in the subwoofer amp we've also added a simple muting circuit, which briefly inhibits signals to both the internal and the main external power amplifiers during power transitions. In practice, the

crossover's mono low-pass and stereo high-pass outputs are muted when power is both applied and removed, so assuming that the actual amplifier modules do not generate significant transients of their own, there is no nasty turn-on or turn-off thumps through any of the system's speakers. And since the amplifier module used in the new subwoofer amp has been developed from the Pro Series Three amplifier design (February/March 1994), which is quite 'thump free', this simple muting system works well.

Which brings us to the amplifier module itself. As you can see from the schematic diagram presented here, the only significant change from the original Pro Series Three design is the addition of a third set of complementary power MOSFETs, Q11 and Q14. These increase both the transconductance and current

capability of the output stage in one stroke, which promotes a larger output swing under load by lowering the output stage's effective 'on' resistance. It also safely spreads the power dissipation through more devices.

The result is a substantial increase in the amplifier's output power capability, so that our new design should satisfy the most power hungry speakers and of course, those with a penchant for ear-shattering volume levels.

We've also taken some effort to ensure that this project is easy to put together, as was the Pro Series Three amplifier. While the amplifier module uses the same simple MOSFET clamping bracket arrangement as before, there is no longer any need to mount the T0-126 driver transistors onto the bracket, as they are now free standing in the main

SPECIFICATIONS

Continuous power output:	200W RMS into eight ohms 320W RMS into four ohms
IHF power output (short term):	240W RMS into eight ohms 430W RMS into four ohms
Harmonic distortion (THD):	0.003% at 180W into eight ohms 0.005% at 300W into four ohms
Signal to Noise ratio (unweighted):	>95dB with respect to 100W RMS
Frequency response:	10Hz to 70Hz/90Hz/120Hz (selectable) (amplifier module: 10Hz to 100kHz, -3dB)
Crossover filtering	-12dB/octave slopes, matched phase for HP/LP outputs
Damping factor:	>300 at 200W into eight ohms
Input sensitivity/impedance:	0.6V/47k for 200W RMS into eight ohms
Overload indicator:	Activated if output THD exceeds approx 0.05% (regardless of load impedance)
Muting:	Applied to both LP and HP outputs at power on/off



body of the circuit board. This has been achieved by reducing the standing current through these devices, thereby eliminating the need for the heatsinking effect of the clamping bracket. Note that there has been no measurable (or discernible) change in the amp's performance through this alteration.

So by combining (plus enhancing) the proven and effective designs from our free standing active crossover and the Pro Series Three amp, we're able to offer a subwoofer amplifier that delivers first class performance and a useful range of features. If you would like to know more about the design philosophy behind both of these past projects, we suggest that you refer back to the relevant issues, as mentioned above.

And by the way, we'd like to thank Jaycar Electronics for their kind assistance in supplying key components and the box assembly for this project.

Crossover circuit

The subwoofer amp's active crossover circuit is identical to free standing unit presented in the September 1994 issue, except that in this case we've added the signal muting circuitry based around IC4 and transistors Q17 to Q19 — as shown in the schematic of the filter circuit.

Considering the filter's left channel high-pass output (SKT2) for a moment, you can see that R43 and the collector-emitter junctions of Q17 form a simple voltage divider at the output of IC1b. This allows Q17 to severely attenuate (mute) the signal when forward biased by a high level on the 'mute control line', which is applied via limiting resistor R44 and isolating diode D5. The diode allows the transistor's base connection to effectively 'float' when the control line is low (muting off), so that large signal levels cannot force Q17's collector-base junction into reverse voltage breakdown.

As you would expect, the two remaining attenuator circuits (based around Q18 and Q19) operate in the same manner, and mute the signals at the mono low-pass and right channel high-pass outputs, respectively. All three circuits are driven from the mute control line which connects directly to the output of IC4, the basis of the power-on/off detector stage.

Here, IC4 acts as a simple comparator with a small degree of hysteresis provided by R73, and ultimately responds to a change in the state of its power supply rails VS+ and VS-. When power is first applied to the unit C52 rapidly charges via D10, applying power to IC4 at pins 7 and 4, while the combination of R70 and R71 set the op-amp's non-inverting input to a level of about -1V.

Since C53 is in a discharged state at this point, the op-amp's inverting input is held at a level close to VS-, thereby forcing the comparator's output high. This then activates the muting transistors Q17 to Q19, as described above, and illuminates the 'mute' indicator (LED5) via R74, Q20 and limiting resistor R75.

C53 then slowly charges via R72 until the voltage level at IC4's inverting input (pin 2) exceeds that of the non-inverting input (pin 3), where the comparator's out-

put returns to a low level and the muting process is terminated. Thus the audio signals to both the subwoofer and main amplifiers are shut off for a short period (about a second) after power is first applied, then passed without restriction during normal use.

When power to the unit is shut off however, a further muting action is generated by IC4 in response to the falling supply rail voltages. In this case, while both VS+ and VS- quickly drop to around zero volts, the positive supply at pin 7 of IC4 is maintained at about 16V by the storage action of C52 — which is isolated from VS+ by D10, of course.

The combination of R70 and R71 then sets the level at the op-amp's non-inverting input (pin 3) at around 7V, while the inverting input (pin 2) is referenced to the 0V line (ground) via R72. Note that D11 provides a rapid discharge path for C53, and prevents the inverting input from rising above 0.6V.

As power is shut off then, the comparator's output is quickly forced to a high level in response to the positive voltage at pin 3, and the muting action is re-enabled. The muting indicator (LED5) will illuminate for a brief period as the supply rails fall, while the actual muting transistors will remain in action until the

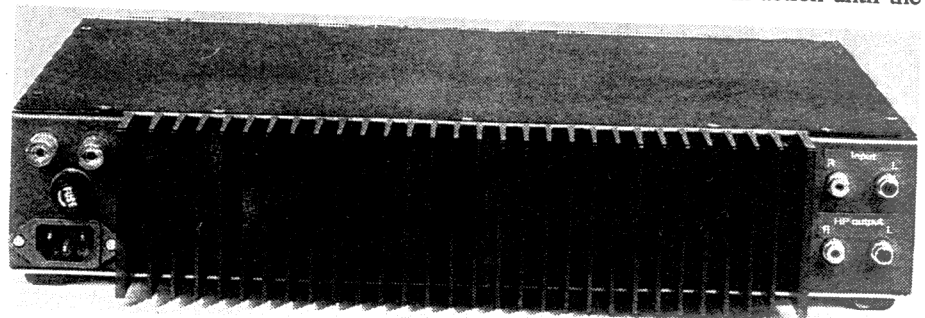

The amp's rear side panels hold the signal in/out sockets (shown on the right) and the speaker terminals plus the mains socket and fuse holder (on the left). While the latter panel is a little crowded, it's quite functional in practice.

Playmaster 300W Subwoofer Amp - 1

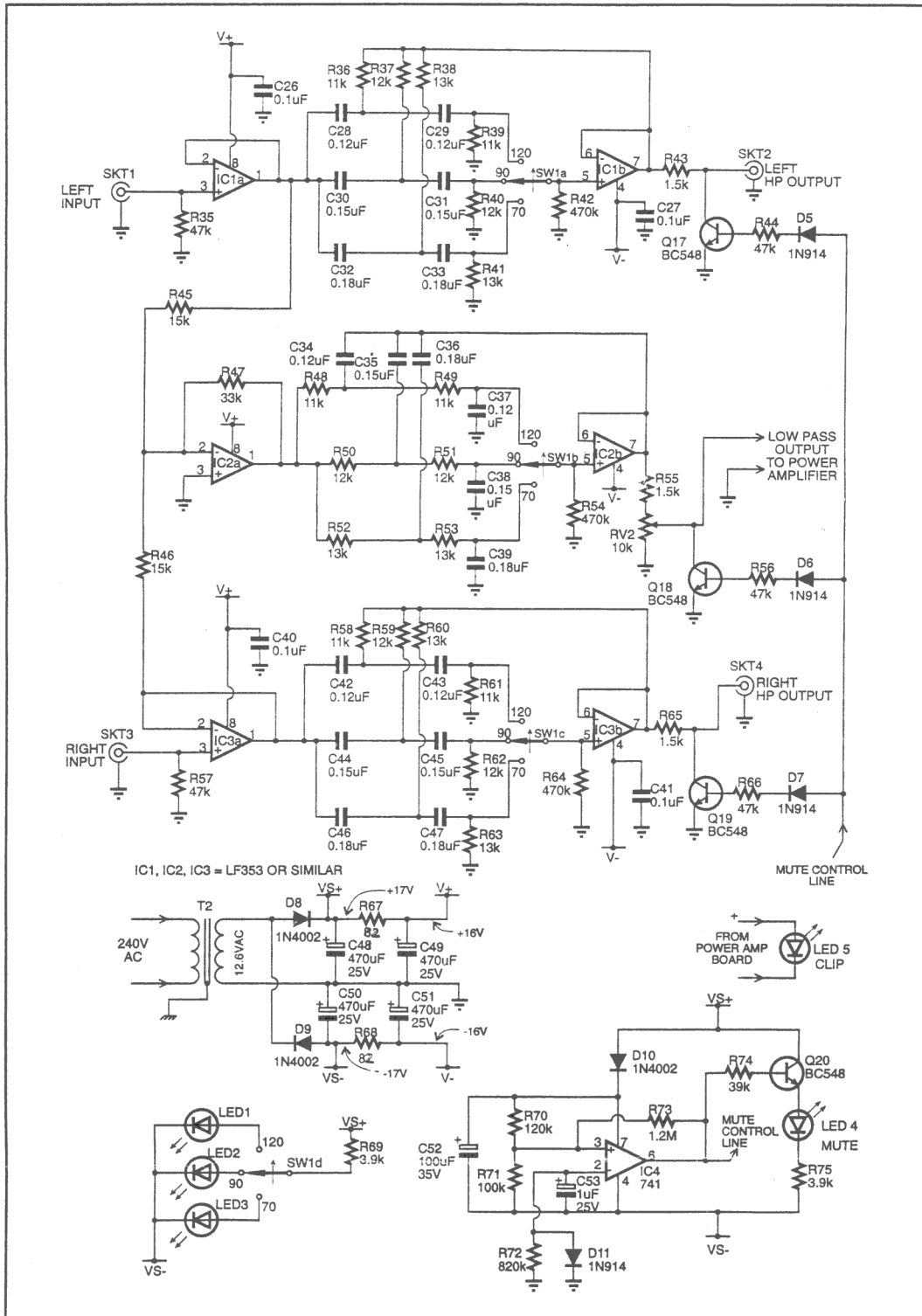

The subwoofer amp's active crossover circuit incorporates three second order Linkwitz-Riley filter stages (one low pass and two high pass), and a simple comparator stage (IC4) to control the signal muting.

output of IC4 finally drops after C52's energy is exhausted.

Other than the muting circuitry, the only real difference between our new circuit and the past design is that we've included the power amp's 'clip' indicator (LED4) on the filter board, as this makes for a neater result and easier construction technique — in fact, all of the filter's in-

dicator LEDs (LED1 through to LED5) are now mounted directly on the circuit board, for these reasons.

The remaining circuitry around the muting stage includes the filter's power supply, and the crossover frequency indicating LEDs. SW1d is used to connect LED1, LED2 or LED3 to current limiting resistor R69, to indicate a

crossover setting of 120Hz, 90Hz or 70Hz respectively.

The power supply itself is a rather basic affair, where the (nominally) 12.6V AC secondary voltage of a 2851-type transformer is half wave rectified by D8 and D9 to produce the positive (VS+) and negative (VS-) supply rails, respectively, and filtered by reservoir capacitors C48

7-780DC
44URMSOUT

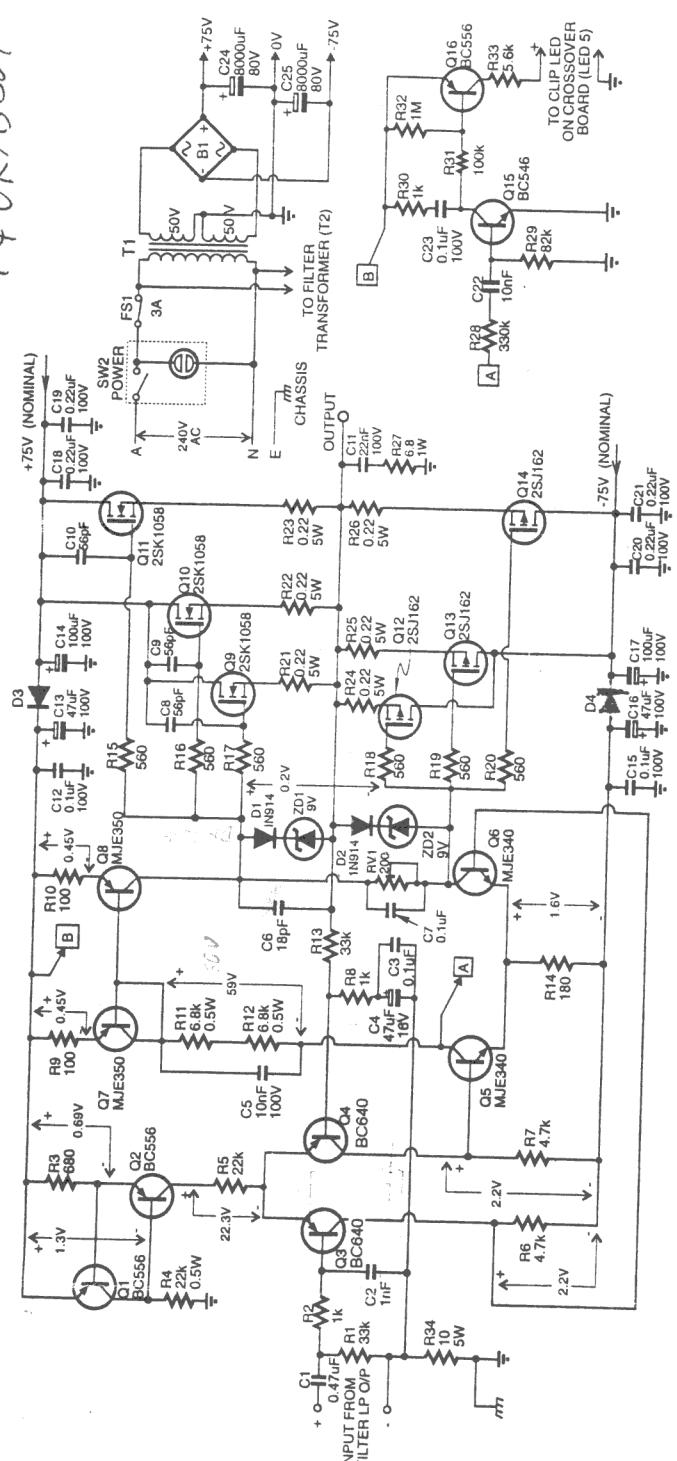

The amplifier module is a beefed up version of the circuit used in our Pro Series Three stereo power amp — note the extra set of complementary power MOSFETs, Q11 and Q14.

and C50. V+ and V- (which supply the op-amps) are then developed through the additional filtering action of R67/C49 and R68/C51, respectively.

As you can see from the remaining sec-

tion of the filter board's schematic, the actual crossover circuit uses three dual op-amps (LF353 type) to produce the left and right channel high-pass signals for the external stereo power amp, and the

mono low-pass signal for the internal amplifier module. All of the filters conform to a second order Linkwitz-Riley configuration, by the way.

Considering the left input for the moment, you can see that IC1a acts a unity gain buffer which passes the input signal to both the following high-pass filter circuit (based around IC1b), and a simple adding stage formed around IC2a. Here, the buffered left and right signals are mixed together with a gain of around two (as set by R45/R46 and R47), then passed to the low-pass filter stage based on IC2b which uses an equal value 'Sallen and Key' network arrangement. Note that there is a separate network for each crossover frequency (encompassing components C34 to C39, and R48 to R53), and these are selected by SW1b.

The high-pass filter stages based on IC1b (left) and IC3a (right) are configured in the same manner as the low-pass circuit, except of course that the filter networks are arranged in a reciprocal manner so as to produce the appropriate high-pass response, with a matching phase characteristic. The left and right outputs at IC1b and IC3b are connected directly to the muting stages as described above, while the low-pass output at IC2b (pin 7) is applied via the subwoofer output level control, RV2.

Amplifier circuit

As with the crossover circuitry, the amp module circuit is an enhancement on a previous and well proven design — in this case, the Pro Series Three amplifier. The arrangement has been beefed up somewhat by the addition of the extra set of power MOSFETs (Q11 and Q14 in the schematic), and a few minor sections of the circuit altered to accommodate this new arrangement.

The amp's basic design is quite straightforward thanks to the simple nature of the MOSFET output stage, and as it happens, was covered in some depth in the Pro Series amplifier articles from previous issues — namely, the Pro Series One amp from December 1989 and the abovementioned Pro Series Three article. So rather than embarking on a long-winded discussion about the circuit here, we'll keep the description brief and recommend that those interested in the finer workings of the circuit refer back to those previous issues.

As you can see from the amplifier's schematic, signals are applied to a differential input stage based around Q3 and Q4, which is fed from a 1mA constant current source formed by Q1 and Q2. The input is isolated from DC by C1, referenced to 0V by R1, while very high fre-

Subwoofer Amp - 1

quencies are attenuated by the low-pass filter formed by R2 and C2. Also, a ground reference is provided by R34, and the voltage drop and power dissipation in Q2 is reduced by the addition of R5.

Signals are then applied to the main voltage amplification stage based on differential amp Q5/Q6, which is loaded by a 'balanced current mirror' pair formed by Q7 and Q8.

Here, the dissipation in Q5 is reduced to that of Q6 by R11 and R12, which also provide a convenient monitoring point for the clipping indicator circuit — see connection 'A'. The highly linear output signals at the ends of RV1 (quiescent current adjustment) are then passed directly to the following MOSFET output stage formed by complementary source followers Q9 to Q14, which use source degeneration resistors R21 to R26 and gate 'stopper' resistors R15 to R20. Excessive gate drive is prevented by clipping networks D1/ZD1 and D2/ZD2, while stability is enhanced by bypass capacitors C6 to C10 and step compensation network C11/R27.

Other than that, overall negative feedback is applied from the output back to Q4 via R13 and R8 (which set the closed-loop gain at around 34) with C4 and C3

completing the AC ground path. The power supply rails are bypassed by C14, C17, and C18 to C21, while the earlier high-gain stages are supplied via isolating diodes D3 and D4, then bypassed by C12, C13, C15 and C16.

The remaining parts of the circuit involve the power supply and clipping indicator stage based on Q15 and Q16. In the latter circuit, any error signals from the main voltage gain stage (Q5/Q6) are both amplified and rectified by Q15, which then charges the pulse extending capacitor C23 via R30. This in turn biases Q16 fully on, energising LED5 ('clip') through limiting resistor R33. In the normal course of events of course, there are no significant error signals present and both Q15 and Q16 are off.

The module's power supply is a basic 'boots and all' affair with a 300VA toroidal power transformer (T1), which has its 100V AC centre-tapped secondary full wave rectified by diode bridge D1. The resulting (nominal) +/-75V DC supply rails are filtered by 8000uF reservoir capacitors C24 and C25 and passed directly to the amp module, as shown in the schematic.

In the second of these articles, we'll cover the assembly and testing of the subwoofer amp.

CONSTRUCTOR PLEASE NOTE:

To mount the RCA sockets on the rear panel, follow the diagram below to properly isolate the RCA sockets from the chassis. The black plastic insulator is pushed-in from the outside of the rear panel, then trimmed-down so that its shaft is slightly proud of the inside of the rear panel. This can be done by using a pair of flush side cutters. After trimming the insulator, the RCA sockets can be mounted as shown here.

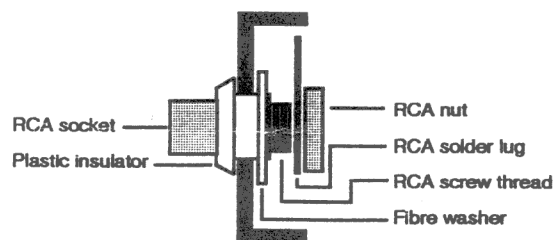

When mounting the illuminated rocker switch to the front panel, it will most probably be necessary to trim one or two millimeters from the tip of the retaining arms moulded to the switch. Simply cut 1mm away at a time from each arm until you achieve a tight fit into the panel. Take care however, not to cut too much off from each arm as this will allow the switch to wriggle about inside its' mounting hole.

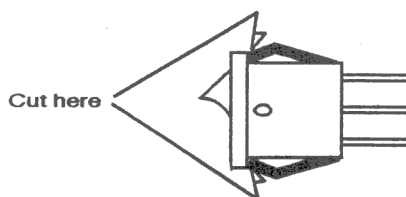

Construction project:

PLAYMASTER 300W SUBWOOFER AMP - 2

Here's the second and final article describing our new subwoofer amplifier, with its impressive power capability of 320W into a four ohm load or 200W into an eight ohm load, and a built in two-way active crossover with selectable cutoff frequencies. In this article the author describes its construction in detail, and also explains how it's set up.

by **ROB EVANS**

As you can see from the photos of the prototype, the subwoofer amp is housed in a metal case based around a single deep-finned heatsink, in a broadly similar manner to the Pro Series Three amplifier. The case matches the external dimensions of the previous design, despite the use here of only one power amp module (installed at the rear) and power supply components, so there's quite a bit of fresh air inside. You can also see that the crossover board mounts onto the front panel in quite a simple manner, and its own power transformer has been installed in the

front right hand corner of the box, near the main toroidal unit.

We've taken some effort to ensure that this new design is quite simple to construct, through the use of a simple clamping scheme to attach the power amp module to the heatsink, plus minimal interwiring between connectors and circuit boards, and a redesigned crossover PCB that now supports all of the unit's indicator LEDs. The crossover board itself is supported by just the two front panel controls.

The subwoofer amp's construction can be broadly divided into two main tasks:

assembling the amp module/heatsink and crossover assemblies, then completing the box and its associated wiring. To make this task as simple as possible, we've also included several diagrams for you to refer to during the assembly process — including of course, the usual component overlay diagrams.

By the way, it's best to follow the assembly order as described below, since some components are much easier to fit in the latter stages of construction. And for reference, the parts for the crossover fit onto a single PCB coded 95ft3 which measures 155 x 63mm, while the amp module board is coded 95swa4 and measures 202 x 78mm.

Commence the construction by assembling the crossover board as shown in the component overlay, working your way through from the lower profile parts (links, resistors) to the larger components such as the electrolytic capacitors, and finally the rotary switch. Don't fit the potentiometer or LEDs at this stage, as they will need to be aligned to the front panel as the crossover assembly is installed in the box.

Note that there are four wire links on the board, that capacitors C19 to C22 are lying on their side (you will need to crank the leads over to suit), and also that PCB pins for the external connections have been fitted to the *copper* side of the PCB. Take particular care with the positioning of the polarised components such as the electrolytic caps and semi-conductors, as their orientation on the board does not follow a regular pattern, and you might like to double check the values of the 1% resistors with a multimeter, since their markings can often be rather difficult to read by eye.

Next, assemble the power amp module by following the same basic procedure

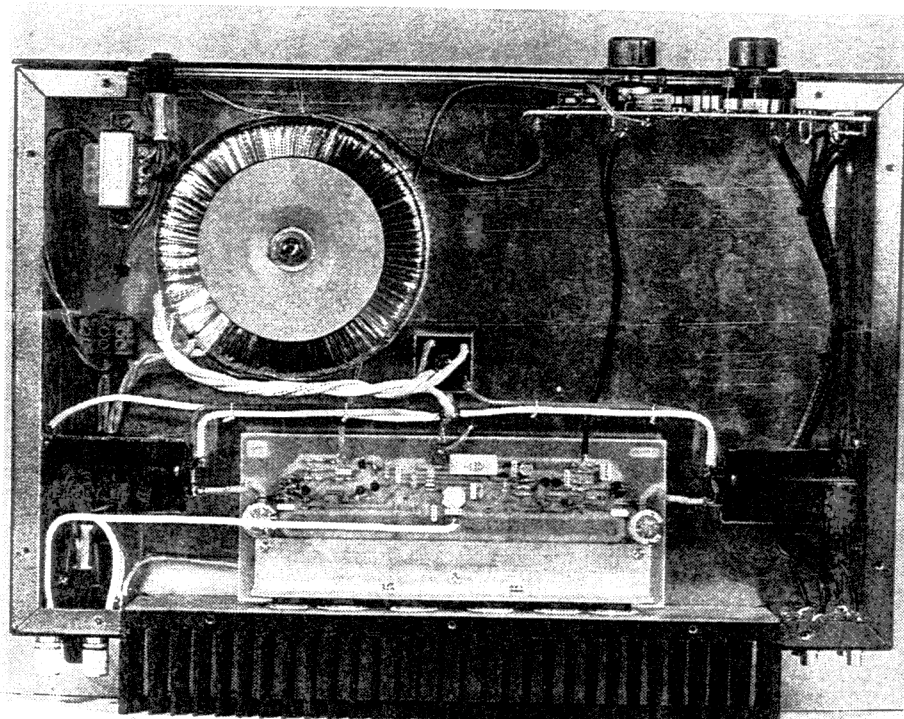

There's plenty of room inside the case, thanks to the compact nature of the amp and crossover boards, and the small amount of wiring used to connect it all together.

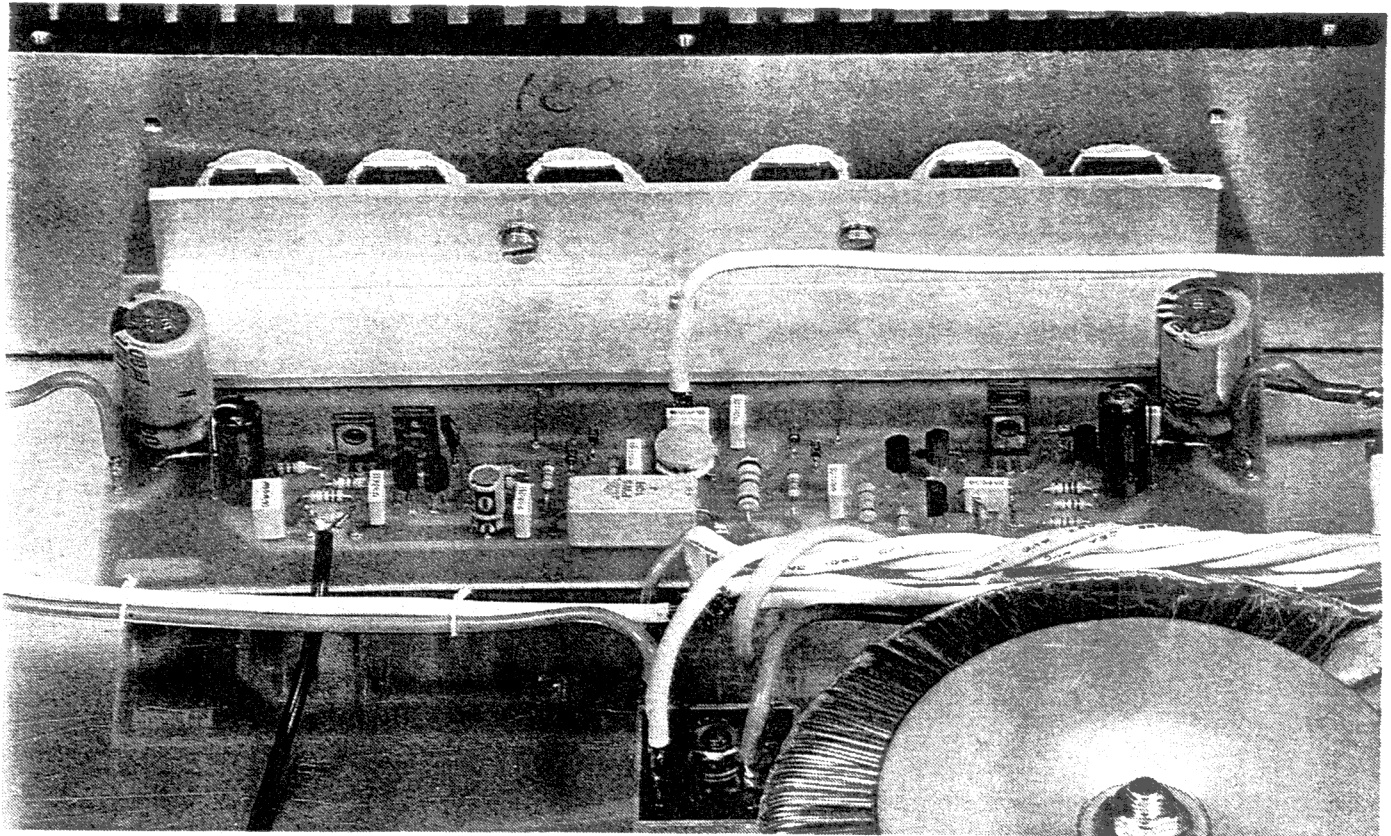

Despite the impressive power output, the new amplifier module is surprisingly small in size. As you can see, it uses a simple aluminium bracket to both support the PCB and clamp the power MOSFETs to the heatsink.

as above. In this case however, there are two links on the board and the PCB pins mount on the component side of the PCB in the normal way. Start by installing the parts as shown in the *component side* overlay diagram, then fit the power MOSFETs, and finally the components on the *copper side* of the board.

As usual, take particular care with the orientation of the semiconductors and the electrolytic capacitors, while referring to the overlay diagrams at all times. As previously mentioned, the four T0-126 driver transistors are no longer bolted to the aluminium bracket as was the case with the Pro Series Three modules, and can therefore be installed at this stage — take careful note of their orientation however. Also note that while we haven't bothered with our prototype, the two BC556 transistors used in the input stage (Q3 and Q4) can be matched in characteristics and thermally bonded together as detailed in the second installment of the Pro Series Three article (March 1994). This provides a small, but arguably audible, improvement in the amp's performance.

Now bolt the aluminium bracket (measuring 180 x 25 x 25mm) to the PCB using three screws, and install the six MOSFETs while using the bracket as an alignment guide. Note that the two

outermost screws should have fibre (or plastic) insulating washers under the nut, so they cannot make electrical contact with the PCB tracks. Once you are happy with the MOSFET positioning, solder their legs in place and then check the location of the bracket. This should be positioned so that the MOSFETs will be evenly clamped to the heatsink surface when the two mounting bolts are installed.

The copper side parts can now be soldered in place, as shown in the matching overlay diagram, while working your way from one side to the other so that

there is always access for the soldering iron barrel. All of the resistors (5W and 0.25W types) will need their leads shaped so that their bodies are slightly elevated above the board's surface and the leads cannot come into contact with any nearby (or spanned) tracks, and both the MKT and ceramic capacitors will need their legs splayed in the same way. Make sure that you don't overheat the latter components, by the way.

After that, the completed amplifier module can be bolted to the heatsink as shown in Fig.1 and the associated photos of the prototype. First, check that the

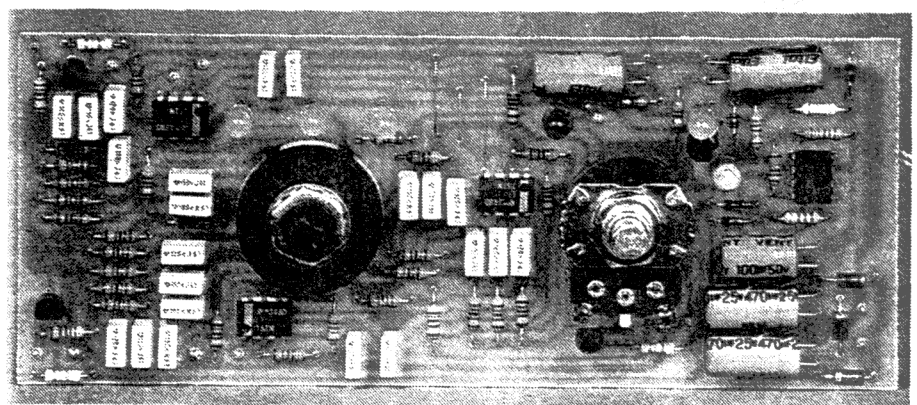

The crossover board mounts directly into the amplifier's front panel, and is supported by the rotary switch and level pot. Note how the larger electrolytics are mounted horizontally, for additional clearance.

PLAYMASTER 300W SUBWOOFER AMP - 2

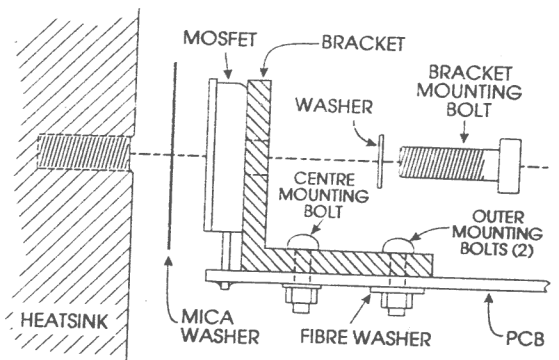
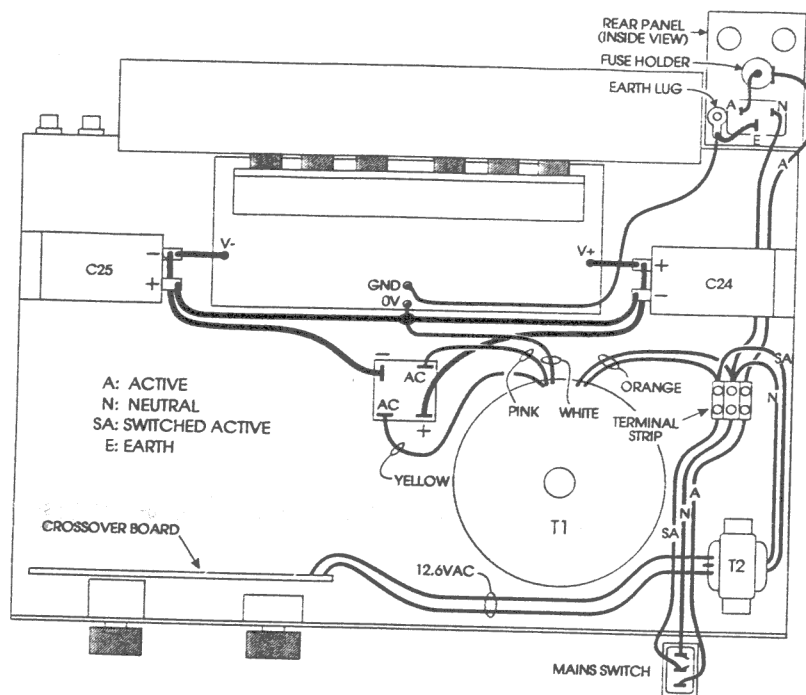

Fig.1 (above): Use this diagram as a guide to fitting both the MOSFETs and aluminium bracket, and when clamping the amp module to the heatsink.

Fig.2 (left): The amplifier's main power connections. Take particular care with the 240V mains wiring, and note that the diagram's heavier

heatsink surface is free from any sharp protrusions, as these may penetrate the mica insulating washers and cause a short. Then coat both sides of the washers with a generous layer of thermal grease and clamp the assembly in place. Check that each washer remains aligned to the MOSFET's metal sur-

face during this procedure, and make sure that you don't overtighten the two mounting bolts.

The subwoofer amp's case can now be assembled around the completed amplifier/heatsink module, and the various plugs, sockets and connectors installed — but leave out the 8000uF filter

capacitors for the moment. Don't forget to include the main earthing lug under the IEC socket's left hand mounting screw (with a lock or 'star' washer), and make sure that the four RCA input sockets are electrically isolated from the chassis — we used plastic inserts and fibre washers for this purpose.

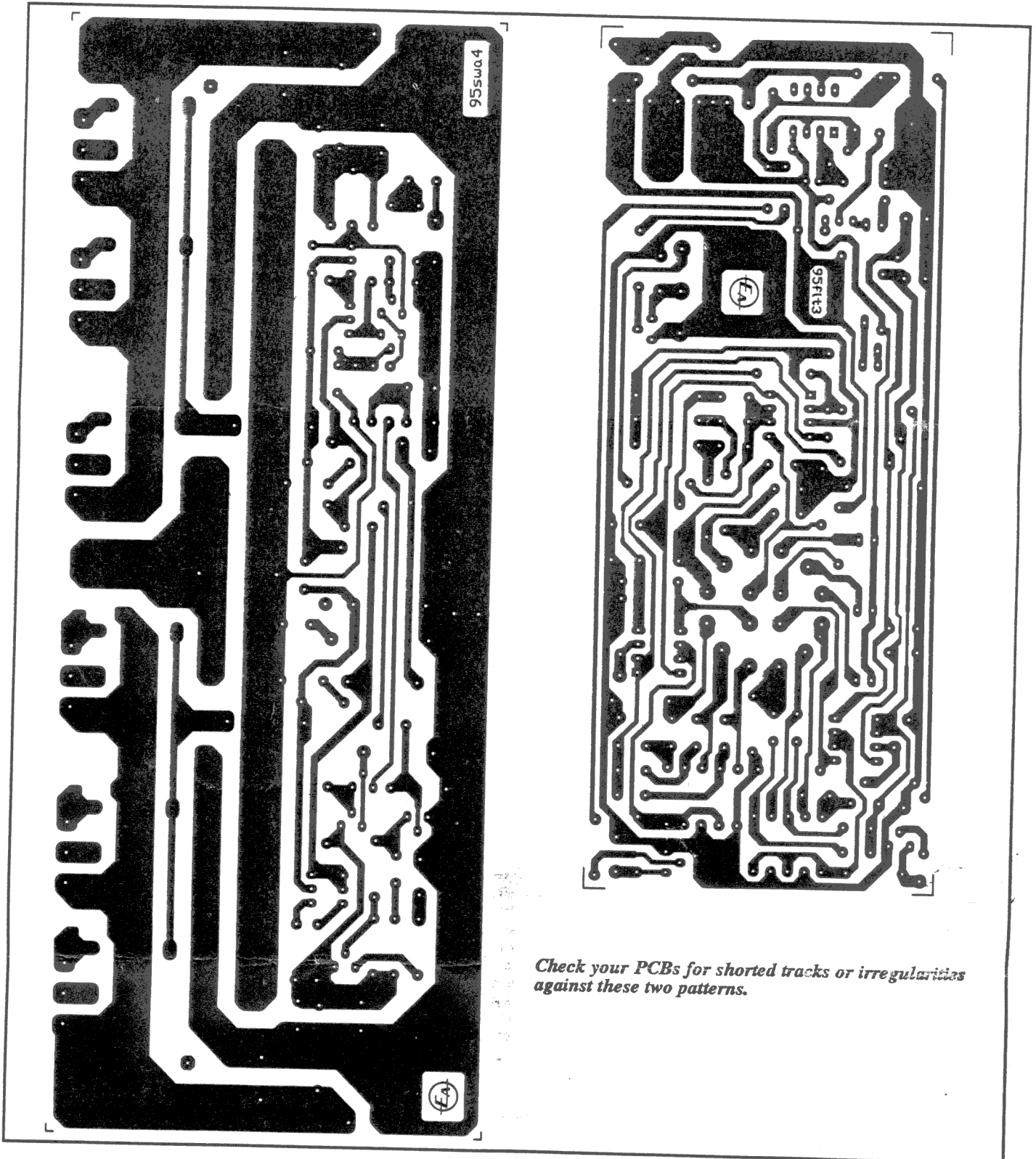

Check your PCBs for shorted tracks or irregularities against these two patterns.

Once the front and bottom panels have been screwed to the side panels, the crossover board can be installed. First, solder three generous lengths of tinned copper wire to the volume pot's lugs and install it to the front panel, with the lugs facing down.

Then fit the LEDs into the PCB as shown in the overlay (without solder-

ing their legs) and slide the assembly into the front panel while feeding the pot's wire stalks through the matching PCB holes.

When you are happy with the crossover module's alignment in the front panel, tighten the rotary switch locking nut and solder (then trim) the pot's wires in place. The LED bodies can then be

pushed into the front panel and their legs soldered to the board — making sure that the orientation of each LED is correct, before you proceed.

Next on the agenda is the mains AC wiring. As you can see from Fig.2 the 240V mains connections enter via the IEC socket and then connect to a short length of terminal strip, with the active

PLAYMASTER 300W SUBWOOFER AMP - 2

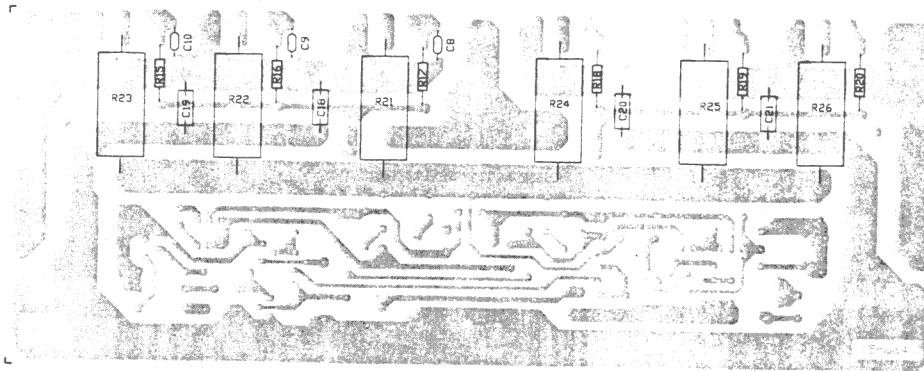

The component overlay diagram for the copper side of the PCB. Install these components last, after the bracket has been attached to the board.

connection passing through a 3AG fuse holder. At this point the neutral directly feeds both transformers (T1 and T2) and the mains switch neon indicator lamp, while the active passes to the transformers via the mains switch contacts — connection 'SA'.

Take particular care with this part of the wiring, and make sure that all exposed connection points are well insulated with tight fitting heatshrink or varnished cambric sleeving. Note that

the 'N' and 'SA' connections on the mains switch can be identified by the small copper wires (the internal neon connections) that emerge through the body at these lugs, and these should face towards the *bottom* of the box when the switch is correctly installed.

The earth/ground wires should also be fitted at this point, as again shown in the diagram. And by the way, if you have difficulty in reaching the connections at the IEC socket with your

soldering iron, try improving the access by temporarily removing the amp module/heatsink assembly.

Next comes the unit's low voltage power wiring, which can be completed as shown in Fig.2 after the 8000uF reservoir capacitors have been installed. Make sure that the high current connections (i.e., all wiring at the reservoir caps) are formed with heavy duty insulated wire, and your soldering iron has sufficient heat capacity for the job. The 0V line between the capacitors is made from two lengths, which are joined just near the amp module's '0V' connection — as depicted by the 'blob' in the diagram.

It's important to note that this main 0V connecting point has *three* other connections (only two are shown). These are the actual 0V point on the amp's PCB (via a length of tinned copper wire), the centre-tap connection of the power transformer's secondary (T1's white wire), and the 0V or 'negative' line to the appropriate speaker terminal post on the rear panel (not shown). Also note that the 'positive' speaker post connection is shown on the amp module's overlay diagram.

When the rest of the wiring has been completed as indicated in the

PARTS LIST

Capacitors

C1	0.47uF 63V MKT
C2	1nF
C3,7,12,15,23	0.1uF 100V MKT
C4	47uF 16VW electrolytic
C5,22	10nF 100V MKT
C6	18pF ceramic
C8,9,10	56pF ceramic (150V)
C11	22nF 100V MKT
C13,16	47uF 100VW electrolytic
C14,17	100uF 100VW electrolytic
C18,19,20,21	0.22uF 100V MKT
C24,25	8000uF 80VW electrolytic, chassis mount
C26,27,40,41	0.1uF MKT
C28,29,34,37,42,43	0.12uF MKT
C30,31,35,38,44,45	

R69,75	3.9k
R70	120k
R71	100k
R72	820k
R73	1.2M
R74	39k
RV1	200 ohm horizontal trimpot
RV2	10k log pot

Semiconductors

D1,2,5,6,7,11	1N914 signal diode
D3,4,8,9,10	1N4002 power diode
ZD1,2	9V 400mW zener diode
Q1,2,3,4,16	BC556 PNP transistor
Q5,6	MJE340 NPN transistor
Q7,8	MJE350 PNP transistor
Q9,10,11	2SK1058 power MOSFETs
Q12,13,14	2SJ162 power MOSFETs

**REFER TO THE PARTS LIST
AT THE BACK OF THIS
MANUAL**

C32,

C48,
C52
C53

Res

All 1,	
R1,1	
R2,8,...	
R3	680 ohms
R4	22k 0.5W
R5	22k
R6,7	4.7k
R9,10	100 ohms
R11,12	6.8k 0.5W
R14	180 ohms
R15,16,17,18,19,20	560 ohms
R21,22,23,24,25,26	0.22 ohms 5W
R27	6.8 ohms 1W
R28	330k
R29	82k
R31	100k
R32	1M
R33	5.6k
R34	10 ohms 5W
R35,44,56,57,66	47k
R36,39,48,49,58,61	11k
R37,40,50,51,59,62	12k
R38,41,52,53,60,63	13k
R42,54,64	470k
R43,55,65	1.5k
R45,46	15k
R47	33k
R67,68	8 ohms

B1 3504-type diode bridge

Miscellaneous

SW1	3-position 4-pole rotary switch
SW2	illuminated SPST mains rocker switch
T1	12.6V/150mA 2851-type transformer
T2	300VA toroidal transformer, 50-0-50V
PCB, code 95swa4; PCB, code 95ft3; 2 x knobs; case with integral heatsink, 300 x 400 x 80mm; IEC mains connector, panel mount; 4 x panel mount RCA sockets (insulated); 180 x 25 x 25mm aluminium bracket; 2 x large binding posts; 3AG fuse holder, with 3A fuse; mains-rated terminal strip; solder lug; 6 x TO-3P insulating washers; PCB pins; audio shielded cable; light-duty hookup wire; heavy-duty hookup wire; mains-rated hookup wire; tinned copper wire; thermal grease; small fibre or plastic washers, 4 x rubber feet; heatshrink or cambric tubing; nuts, bolts and lockwashers; etc.	

diagrams and shots of the prototype, the unit can be tidied up, the knobs and mounting feet fitted, and you're ready for the test flight.

Powering it up

Before applying power to the unit, rotate trimpot RV1 on the amp module fully *counter clockwise* (zero ohms) for a minimum output stage bias current setting, and temporarily install a 10 ohm (0.25W) resistor in series with each supply rail — the 'V+' and 'V-' PCB pins are the most convenient positions.

Then apply power to the unit, confirm that the supply rails measure close to +/- 75V, and set the voltage drop across the 10 ohm resistors to about 0.8V by slowly

adjusting RV1 in a clockwise direction. While the bias current for this type of MOSFET design is not overly critical, the 0.8V figure represents a total idling current of about 80mA, which is quite adequate for this application.

Next, switch the unit off, remove the 10 ohm test resistors, then re-apply power while observing the state of the 'mute' LED on the front panel — if all's well, this should illuminate for a moment after power is connected (and again when it's disconnected). If this is not the case, check that the crossover's VS+, VS-, V+ and V- supply rails measure close to their specified levels and the LED is installed with the correct orientation.

Once you're confident that all's well, the subwoofer amp can be wired into the signal path of an existing system, and a suitable subwoofer connected to the speaker terminals. The optimum crossover frequency setting (120, 90 or 70Hz) can be determined on either a purely subjective basis, or judged from frequency response plots of the speakers involved.

For example if the subwoofer has little output above 100Hz, a crossover point of 90Hz or 70Hz would be prudent. Conversely if your main speakers run out of steam below 100Hz, the crossover setting of 120Hz would be in order. In the final analysis however, your ears will be the best judge of both the crossover point *and* the volume balance between the subwoofer and main speaker systems.

Another point that's worth considering at this stage is the power capability of the new subwoofer amp itself. While it's able to deliver a high level of continuous power as indicated in the specification panel, it's worth bearing in mind that the amp can also provide a *much* higher output power for a brief periods, such as during normal music transients. This in turn means that the driver(s) in your subwoofer enclosure could be damaged through excessive cone travel, despite a healthy nominal power rating.

In short, this amplifier has an enormous amount of 'grunt' available, so take care...♦