

aem project 6005

A 100 watt 'ultra-fidelity' topology MOSFET amp module

Part 1

David Tilbrook

Technical Systems Australia Pty Ltd

Spawned as a result of considerable reader demand, this amp module employs the 'ultra-fidelity' circuit arrangement of David's 6000 power amp in a lower power, lower cost design that has numerous applications – undoubtedly a popular one being a 'drop-in' replacement for the modules in his legendary Series 5000 stereo amp.

THE AEM6000 Ultra-fidelity Power Amplifier was published in the June, July, August and September 1986 issues. Some of its distinguishing features compared to earlier designs were the use of a JFET/bipolar cascode input stage, a dc-coupled feedback loop, a mixed asymmetric/symmetric topology and a capability to run from 75 volt rails providing a maximum output power of over 240 watts into an 8 ohm load. In order to accommodate the higher supply rails a new type of output power MOSFETs were employed, the Hitachi 2SJ56/2SK176, with significantly higher voltage capabilities than the earlier 2SJ49/2SK134 MOSFETs. Unfortunately, the new devices are significantly more expensive than the earlier types and the requirement for a high voltage power supply tends to make the project more expensive than other kit power amplifiers. It should be emphasised however, that the AEM6000 is very inexpensive when compared to comparable commercial 240 watt power amplifiers. Nevertheless, we have had many requests for a less expensive 100 watt version employing the same topology as that of the AEM6000 but which is simpler to construct and requires a less expensive power supply.

After looking at the problem we decided to design the module so that it could be incorporated within the Series 5000 metalwork so that owners of Series 5000 power amplifiers could upgrade using the new module. The new module is designated the AEM6005 Ultra-fidelity Topoly Power Amplifier as it employs exactly the same topology as that developed for the AEM6000. The values of resistors R6 and R7 have been changed to 22k and the MOSFETs used are also different as discussed above. In this design we have employed the 2SK134 and 2SJ49 devices which we used in the earlier Series 5000 circuit. So if you are converting a Series 5000 power amplifier to a Series 6005, the power MOSFETs can be removed from the old module. The printed circuit board for the 6005 has been designed to be a similar size to the Ser-

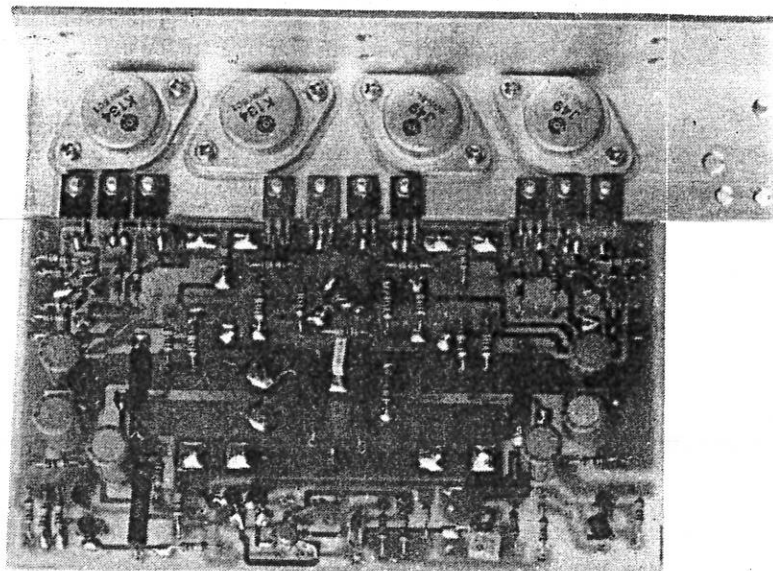

Topside view of the completed module, here mounted to a heatsink bracket to take two modules prepared for mounting in a 5000 amp chassis.

ies 5000 printed circuit board although a different heatsink bracket is required, since in the case of the 6005 module, the drive transistors have been incorporated on the heatsink bracket along with the output devices. This helps simplify construction as well as ensuring the best possible heatsinking for the drive transistors.

The recommended supply voltage for the 6005 module is 50 volts, which means it can be connected directly to the power supply within the 5000 power amplifier. Full details for the installation of two 6005 modules into the 5000 chassis will be dealt with next month, together with drilling details for an appropriate heatsink bracket. The circuit diagram for an alternative dual power supply version will also be dealt with. The drilling details of the heatsink bracket required for a single module are published elsewhere in this article.

The design of the AEM6000/AEM6005 power amplifier modules was based upon a great deal of experimentation to determine an overall circuit topology which would provide the best possible subjective performance. The resulting circuit does not use excessive amounts of overall feedback but derives its low distortion figures by ensuring that each separate voltage amplifier stage is provided with sufficient local feedback and is of such a type to maximise slew rate, for the output stage and the rest of the stages, to minimise the possibility of distortion produced by slew limiting. This provides a further advantage — that of ensuring maximum overall amplifier stability characteristics. ▶

A final and very important characteristic of the topology employed within the AEM6000/AEM6005 power amplifier modules is that of a completely dc-coupled feedback loop. In order to accommodate this, a special cascode input stage was developed which employs both bipolar transistors and a dual JFET in a cascode differential pair configuration. The following discussion covers major aspects of the design and, while many points have been raised in the 6000 articles, their re-iteration is in the context of this design, while the rest of the discussion concentrates on points specific to this project.

The output stage

The output stage for the AEM6005 employs two pairs of Hitachi complimentary power MOSFETs. The N-channel device is a 2SK134, while the P-channel device is the 2SJ49. As mentioned earlier, these are the same power MOSFETs employed in the Series 5000 design and in the AEM6500 general purpose power amplifier modules, the latter being described in the July 1985 issue. The AEM6000 power amplifier module employs the 2SK176 and its complement, the 2SJ56, which are rated for a maximum drain to source voltage of 200 volts. In the case of the 6005 power amplifier module however, the maximum recommended power supply voltage of 50 volts enables the lower voltage MOSFETs to be employed and these are substantially less expensive, as mentioned above.

The 2SK134 and 2SJ49 are rated for use with a maximum drain to source voltage of 140 volts. In a power amplifier employing plus and minus 50 volt rails the maximum instantaneous supply voltage which will be expressed across either pair of output devices will be around 100 volts, which is well below the rating for these devices. This condition will occur when the power amplifier is driven into clipping with no load attached.

Like the AEM6000, the 6005 is a class AB power amplifier. The term class A refers to a mode of operation of an active device whereby the device remains in a conductive or on state for both positive and negative half cycles of the amplified signal waveform. The term class B refers to a different mode of operation whereby the active device is turned off by the signal waveform for some portion (generally half a cycle, or 180 degrees) of the amplified signal. In this case, two active devices are necessary to handle each half of the signal waveform. If this is not done, very large amounts of distortion are generated. Where the output device, or devices, conduct for less than half the input cycle, the stage is said to operate in class C. If only part of each input half cycle is amplified, clearly large amounts of distortion are generated.

The lowest distortion output configuration is class A, with class B representing a compromise between the distortion performance of the class A mode of operation and that of the class C. Since the aim of all power amplifier designs, at least for high quality audio applications, is to reduce distortion it would seem obvious to employ the class A mode of operation exclusively. Although there are several pure class A power amplifiers available on the market today, the vast majority of power amplifiers employ a compromise between class A and class B operation which is referred to as class AB.

The reasons for this are best understood by considering the design of a basic output stage such as that shown in Figure 1. This particular output stage uses power MOSFETs as the two active output devices, although bipolar transistors could just as easily have been used. The drain of the N-channel MOSFET is connected to a positive supply rail while the drain of the P-channel MOSFET is connected to a negative supply rail. The sources of the two devices are connect-

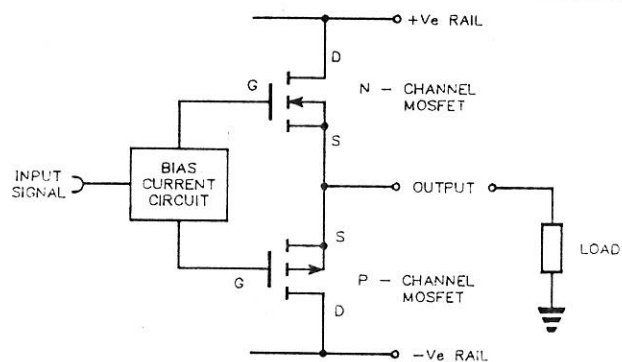

Figure 1. Basic audio amplifier output stage.

ed together and form the output terminal of the stage. The gates of the devices are driven from a bias current circuit which maintains a voltage difference between the two gates sufficient to bias on the two power MOSFETs.

If the bias current circuit was set to zero so that the dc voltage on the two gates was identical, then with zero input signal neither the N-channel MOSFET nor the P-channel MOSFET would be on and hence no current flows on the positive rail. This is class B operation. If a positive input signal is applied, the N-channel MOSFET is biased on while the P-channel MOSFET remains in the off state. Current flows from the positive rail via the N-channel MOSFET to the output and then via the load to ground. Similarly, if a negative input signal is applied the P-channel is biased on while the N-channel MOSFET is turned off and the current flows from earth through the load into the output and via the N-channel MOSFET to the negative rail.

Only one of the two power MOSFETs is active at any time and the transition from one device to another, which occurs at the zero crossings of the input signal waveform, generates a distortion known as "crossover distortion". Since the voltage range over which crossover distortion occurs is constant it will occur over a larger proportion of a small output signal than a larger output signal, and hence is more noticeable at lower signal levels.

If a bias current circuit in Figure 1 is now activated so that a dc voltage is produced between the two gates then both the N-channel MOSFET and the P-channel MOSFET will be turned on simultaneously and current will flow directly from the positive rail via the N-channel MOSFET to the P-channel MOSFET and finally to the negative supply rail. This current is commonly referred to as the bias or quiescent current. If the bias current is set sufficiently high so that it exceeds the maximum peak output current which can be pulled by the load then the output stage to be operated in class A. For a 100 watt output stage to be operated in class A, the bias current must exceed the peak current necessary to produce 100 W in an 8 ohm load, i.e. some five amps. Since the rail voltage on the 6005 is 50 volts, the resulting power dissipation in each of the power MOSFETs will be 250 watts!

This is the main reason class A amplifiers are not more widely used since, although their distortion performance is excellent, this level of quiescent power dissipation is impracticable for most purposes. If the same power amplifier, for example, were to be rated for operation into a 1 ohm load, the bias current would have to be increased to 10 amps with a consequent increase in power dissipation to 500 watts per MOSFET. The complete power amplifier would dissipate something like 1000 watts in heat which is equivalent to a single-bar radiator.

In order to overcome the heat dissipation problems of pure class A designs and the poor distortion figures of pure class

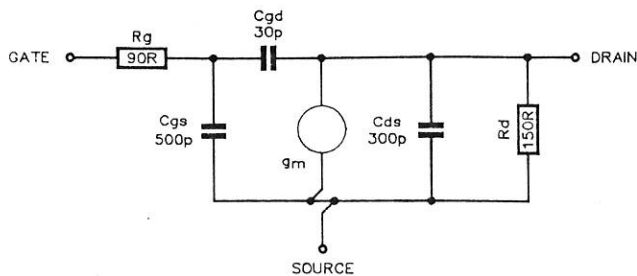

Figure 2. Equivalent circuit of a typical power MOSFET.

B designs, most designers employ a compromise between these two, known as class AB. In this case, the bias current is adjusted so that a relatively small amount of bias current flows through the N-channel and P-channel MOSFETs. Fortunately, even a small amount of bias current has a dramatic effect on crossover distortion. In the 6000 and 6005 power amplifier modules, the output stage drain-source bias current is set at nominally 100 mA and an analysis of the distortion characteristics of the output stage reveals the crossover distortion is completely unmeasurable, being well below the level of noise and other types of distortion mechanisms.

MOSFET versus bipolar

The choice of power MOSFETs in the output stage of an audio amplifier, rather than conventional bipolar transistors, is made because of other important advantages MOSFETs provide. The first of these is that the power MOSFET provides very high gate impedance at low frequencies. This is illustrated by looking at the equivalent circuit of a power MOSFET which is shown in Figure 2. The gate appears as a 90 ohm resistance in series with a capacitance to the drain of 30 pF and a capacitance of 500 pF to the source. At dc, the input resistance is determined by the resistance of the dielectrics of these two effective capacitances, this being several thousands of megohms. Although the input impedance is very high for low frequencies, the input capacitances become increasingly important as frequency is increased and, although the power MOSFET is capable of switching at very high speeds, these input capacitances must be overcome by the drive stage.

The equivalent circuit also gives us insights into several other important characteristics of power MOSFETs. The high frequency performance of the MOSFET is determined by the RC capacitance C_{gs} , as shown in Figure 1. The cutoff frequency of a power MOSFET is therefore well in excess of 3 MHz when correctly driven. Furthermore, the absence of an effect which occurs in bipolar transistors called "minority carrier storage" ensures that the power MOSFET is unrivalled in switching speed and is orders of magnitude faster than most bipolar transistors with similar current ratings. The high speed of the power MOSFET enables the output stage of a power amplifier to be as fast if not faster than the voltage gain and differential stages preceding it and this greatly assists to ensure complete stability of the feedback loop and freedom from slew-induced and other dynamic distortion mechanisms.

Power amplifiers employing slower output devices rely on negative feedback to linearize the high frequency performance of the power amplifier. In this case the amount of overall negative feedback decreases with increasing frequency leading to increased distortion figures at higher frequencies.

One of the most important advantages of power MOSFETs over bipolar transistors for use in the output stages of pow-

er amplifiers is not revealed by the equivalent circuit. Bipolar transistors have a positive temperature co-efficient. If the base to emitter current flowing in a bipolar transistor is held constant, then the resulting collector-to-emitter current will vary proportionately with temperature. If the temperature rises, then so too will the collector-emitter current. The increased current increases power dissipation within the device and the resulting increase in the operating temperature leads to a further increase in collector-emitter current. The resulting effect is called thermal runaway and is the most common cause of output stage failure in power amplifiers employing bipolar output devices. Destruction can be extremely swift.

The power MOSFET, on the other hand, has a negative temperature co-efficient. An increase in drain-source current causing an increase in power dissipation within the power MOSFET will result in an increase in the drain-to-source resistance which tends to oppose any further increase in drain-source current. The power MOSFET is therefore a significantly more robust device than similarly rated bipolar transistors.

The negative temperature co-efficient of power MOSFETs gives rise to yet another advantage over bipolar transistors. The positive temperature co-efficient of bipolar transistors leads to an effect called "secondary breakdown" which limits the area of safe operation within a bipolar transistor when a concentration of current builds up on any part of the chip area. Associated with this increase in current density there will be an increase in power dissipation resulting in a local temperature rise in this region of the chip's surface. The resulting temperature rise causes an even greater increase in current density through this small region of the chip surface resulting in a hot spot which rapidly burns a hole through the chip and destroys the device.

In the case of power MOSFET, however, the negative temperature co-efficient ensures that the current density is spread evenly throughout the chip surface since any increase in current density in a local area will result in an increase in resistance of this area of the chip surface tending to spread the current more evenly over the remaining surface. The absence of secondary breakdown in power MOSFETs is a very important advantage of power MOSFETs over bipolar transistors.

The voltage gain stage

The bulk of the voltage gain of the power amplifier is produced by a fully symmetric differential voltage amplifier which is formed from transistors Q15, Q16, Q17 and Q18 in the main circuit diagram. A fully symmetric voltage amplifier circuit was chosen after experiments into various voltage amplifier topologies showed that the fully symmetric circuit produced the least third harmonic distortion and has the best subjective performance.

This circuit is superior to both asymmetric differential voltage gain stages and symmetric non-differential voltage gain stages. One of the big advantages of the symmetric differential voltage gain stage is that it maximises the linearity of the ►

LEVEL

We expect that constructors of an

INTERMEDIATE

level, between beginners and experienced persons, should be able to successfully complete this project.

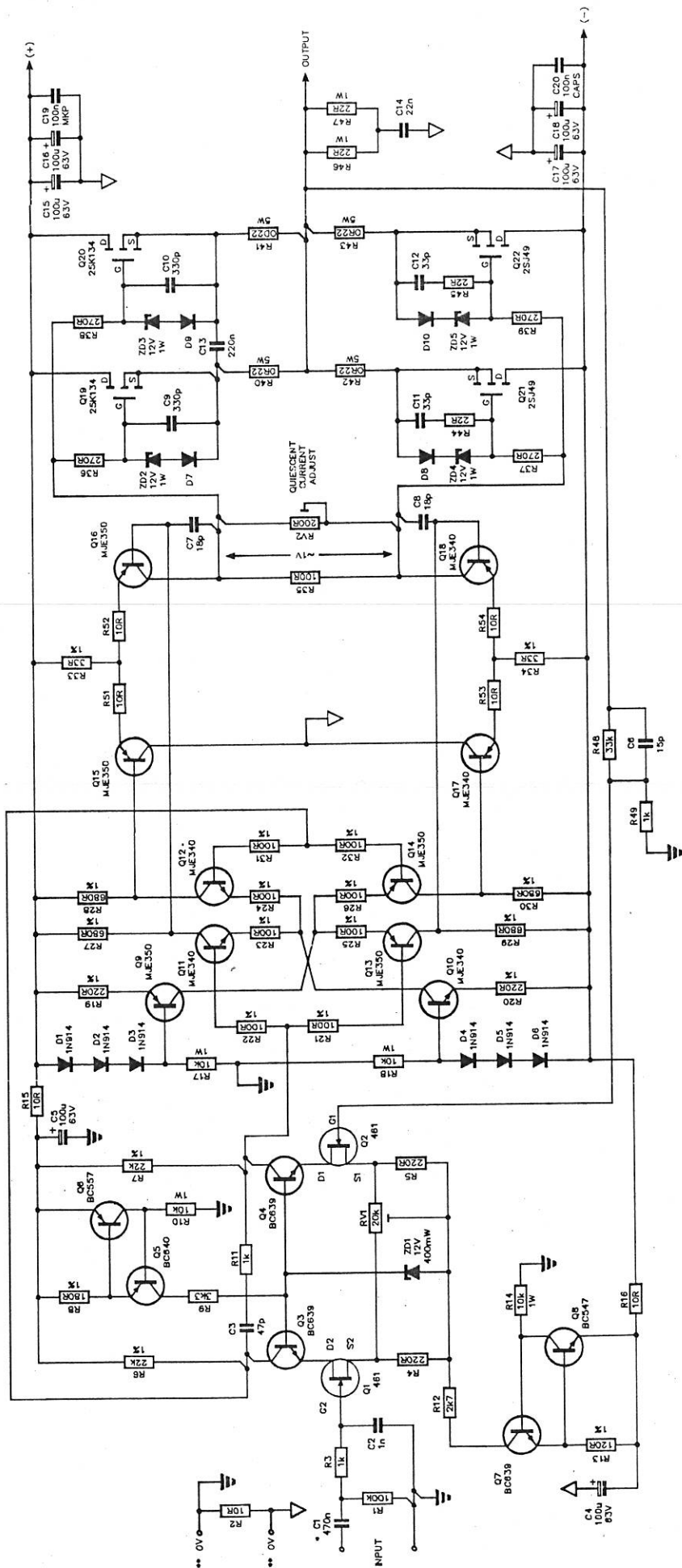

* C1 IS OPTIONAL BUT RECOMMENDED - SEE TEXT
 ** LOG TOGETHER ONLY AT POWER SUPPLY
 † Q1-Q2 - ECG-461 IS A DUAL VET BY NEW TONE ELECTRONICS (NTE)
 ‡ MOUNTED ON HEATSINK
 †† D7-D10 ARE 100V 1A FAST RECOVERY DIODES

▽ NOISY EARTH
 ▽ CLEAN EARTH

N.B. THESE EARTHS MUST REMAIN SEPARATED ON THE P.C BOARD
 RUN SEPARATE WIRES TO THEM FROM THE POWER SUPPLY
 FILTER CAPACITORS.

DRILLING DETAILS: 6005 MODULE
 HEATSINK BRACKET.

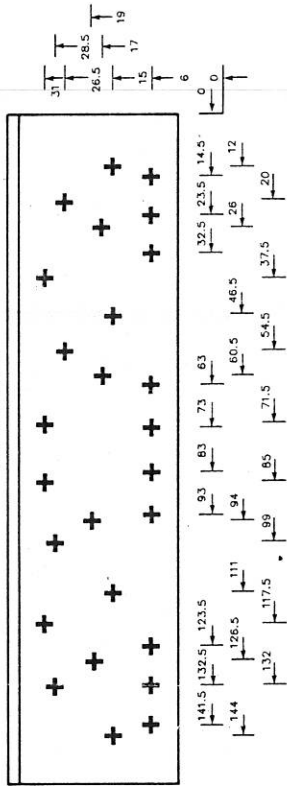

MATERIAL: 40 X 40 X 3mm ALUMINIUM EXTRUSION

See our 'PROJECT BUYERS GUIDE' this issue for a guide to component sources and kit suppliers.

CIRCUIT OPERATION

The input signal is coupled via capacitor C1 to resistors R1 and R3. This capacitor provides dc decoupling, preventing any dc component of the input signal from being connected to the input of the power amp. With the exception of this capacitor, the entire power amplifier is dc coupled, so the gain of the circuit at dc is the same as that for signals within the audio passband, i.e. around 34 with the feedback components specified. This will be covered in greater detail later, but it implies that the application of 1 Vdc to the input without the dc blocking capacitor installed, would result in roughly 34 Vdc appearing at the output of the power amp and hence to the bass driver of any loudspeaker system connected. This, of course, would result in very rapid destruction of the bass driver. The use of C1 therefore, although still optional, is highly recommended.

Resistor R3 and capacitor C2 form a low-pass first-order RC filter, the purpose of which is to limit the maximum signal slope of the input signal. If it is assumed that the output impedance of the preamp used in conjunction with the power amp is significantly less than the value of R3 (1k), then the -3 dB point for this filter is given by the simple equation:

$$f = 1/(2\pi RC)$$

where f is the -3 dB point

R is the resistance of R3

C is the capacitance of C2.

$$\text{i.e. } f = 1/(2\pi \times 10^3 \times 10^{-9}) \\ = 159 \text{ kHz.}$$

This frequency clearly lies well above the audio passband and therefore has no effect on the frequency response performance of the power amp. Its purpose, as mentioned above, is to limit the maximum signal slope of the input signal. This is necessary to help to ensure complete freedom from slew induced distortion, sometimes referred to as TIM, or transient intermodulation distortion. This type of distortion is analogous to a more commonly understood distortion mechanism, that of clipping. In the case of clipping, distortion is generated when the input signal drives the power amp output beyond the limits of its available supply voltage. In a similar manner, if you attempt to drive the power amp beyond its maximum slew rate, the signal 'clips' or 'hard limits' and gross distortion results with products spreading across the audio spectrum. The solution is to design an amplifier with excellent slew rate figures and then to limit the maximum signal slope by the use of simple high frequency low-pass filter so that the slew rate limit of the design cannot be approached.

The effectiveness of this approach is, to a certain extent, dependent on the quality of the input filter. It is important to ensure that the filter employed introduces minimum signal degradation of its own. It is for this reason that the simple first-order RC is used which seems to introduce negligible, if any, degradation of the subjective or objective performance, provided the right type of capacitor is employed. A ceramic capacitor, for example, should not be used in this application. Ideally, use a polypropylene capacitor if one is available or, alternatively, use a good quality MKT type metallised polyester capacitor. Polypropylene capacitors are, unfortunately, very difficult to obtain in Australia in small quantities and also tend to be expensive, but they exhibit clearly superior characteristics in audio signal applications in comparison to many other types. This is also true for the other capacitors in the power amp, not just the input capacitor, C1, but the two high-frequency power supply decoupling capacitors C19 and C20 as well.

Resistor R1 provides a dc reference for the gate of the first of the

JFETs (Q1) which, in conjunction with Q2 (also a JFET), forms the input differential pair. Note that Q1 and Q2 are a dual-JFET contained within a single encapsulation, fabricated on the same substrate to ensure close thermal coupling. Its use is necessary since this power amplifier is entirely dc-coupled and as mentioned above, the gain of the amp at dc is the same as that for signals within the audio passband. If separate transistors are used, each device is free to 'float' at a different temperature (no matter how slight that may be) and a drifting dc offset will result. JFETs are used in preference to bipolar transistors since the JFET requires negligible bias current. If bipolar transistors were used the base-emitter current required produces a dc voltage drop across the bias resistor R1 which, after amplification by the dc voltage gain of the power amplifier, will produce significant levels of dc offset at the output.

The entire input stage actually consists of the dual-JFET described above, in combination with a cascade pair of bipolar transistors, Q3 and Q4. The operating conditions for the input stage are determined by a pair of constant-current sources and the zener diode ZD1. The first current source is formed from transistors Q7, Q8 and their associated resistors R13 and R14. At the moment power is applied to the circuit current flows from the clean earth via R14 through the base of Q7 to the base of Q8 and resistor R13. When the voltage developed across R13 reaches 0.64 V, transistor Q8 is biased on and current flowing through R14 is robbed from the base of Q7. The circuit stabilises so that the current flowing through R13 is such that the voltage across it will be around 0.64 V. This is true regardless of the actual value of resistor R13, so varying the value of this resistor enables the current through it to be varied. Furthermore, once the value of R13 has been chosen, the circuit maintains the current through it at a constant level and the circuit acts as a constant-current source, or actually a constant-current sink in this case. With the value of resistor R13 set at 120 ohms, the current sink will set the current flowing through resistor R12 to 0.64/120 = 5.3 mA.

Resistor R12 is included for two reasons. Firstly, it drops a constant voltage as a result of the constant current flowing through it to decrease the power dissipation in the current sink. Since the current is set by the constant-current sink at around 5.3 mA, a voltage drop of around

$$5.3 \times 10^{-3} \times 2.7 \times 10^3 = 14.4 \text{ volts}$$

will be produced. Secondly, it acts to protect the input stage in the event of a failure of the constant-current sink.

The current set by the constant-current sink flows through the two cascade differential pairs Q1, Q3 and Q2, Q4 as well as through the zener diode ZD1, which provides a dc reference for the bases of the cascade pair. In order to ensure that the differential pair is fed from a constant current to ensure maximization of the common mode rejection ratio (CMRR), it is necessary to use a second current source specifically for the zener diode. This current source is formed from transistors Q5, Q6 and their associated resistors R8 and R10. This constant-current source works in an analogous manner to that formed from Q7 and Q8 and establishes a current of 0.64/180, or around 3.6 mA. This current flows through the 33k resistor R9, which serves the same purpose as that of R12, and produces a voltage drop of around 11.9 volts. The current available to flow through the differential pair is the difference between the currents set by these two differential pairs, i.e. around 1.18 mA. This current is shared equally between the two cascade differential stages so that a current of around 900 μ A flows through the 22k resistors R6 and R7 producing a voltage drop across these of around 22 V.

The second stage is a fully symmetric differential amplifier employing the bipolar transistors Q11, Q12, Q13, Q14 and their associated

resistors R21 to R32. The operating point for this stage is established by a pair of constant-current sources formed from Q9, Q10, R17-R20 and diodes D1-D6. The operation of this type of constant-current source can be understood by considering the negative current source first. The three diodes in series are biased on by current flowing through R18 from the clean earth to the negative rail. The current produces a voltage drop across each of approximately 0.7 V, giving a total voltage drop of 2 V. Since this is applied to the base of Q10, the voltage drop across resistor R20 is also constant giving rise to a constant current through it and hence through the emitter-collector junction of Q10. Since the voltage applied to the base of Q10 is 2 V, around 1.5 volts will be applied across resistor R20, giving rise to a current of $1.5/220 = 6.8$ mA.

The current delivered by the constant current sources to the differential voltage amplifier is shared equally between the load resistors R27 and R28, producing a voltage drop across these resistors of around 1.9 V. This voltage biases the final and main voltage amplifier stage comprising Q15-Q18 and their associated resistors R33, R34, R51-R54 and capacitors C7 and C8. The application of 1.9 V to the bases of this stage causes a voltage of around 1.3 V to be expressed across resistors R33 and R34 and establishes the bias conditions for this stage. Since R33 and R34 are 33 ohms the current is set at $1.3/33 = 40$ mA. This is a relatively large amount of operating current and is necessary to ensure that this stage has a sufficiently low output impedance to drive the input gate capacitance of the MOSFET final output stage. This helps to ensure very good open loop bandwidth which is essential for amplifier stability and freedom from slew induced distortion.

The final stage of the amplifier is the MOSFET current amplifier formed from the four power MOSFETs Q19-Q22 plus associated resistors and capacitors. The bias current for the output stage is set by adjustment of the preset potentiometer RV2. Since the current flowing through this preset is constant, the voltage dropped across it will be directly proportional to its resistance. As the voltage is increased by increasing the resistance of the preset, the output MOSFETs are biased on and a quiescent current will flow from the positive rail to the negative rail through the MOSFETs. This is necessary to provide an area of class A operation to decrease crossover distortion and other nonlinearities that occur at low signal levels. Resistors R36-R39, in conjunction with the gate-to-source capacitance of the power MOSFETs, produce a low-pass first-order filter with a -3 dB point around 1 MHz which is necessary to ensure stability of the output stage. In addition, capacitor C13 acts to prevent oscillation that can occur because the two 2SK134s and the inductance of the source resistors R40 and R41 form a push-pull Colpitts oscillator circuit.

The source resistors have been included to linearise the transfer characteristics of the MOSFETs and also to assist current sharing between the two sets of MOSFETs. Some recently published designs employing power MOSFET output stages have omitted the source resistors, adopting the approach that the negative temperature coefficient of the MOSFETs makes these resistors unnecessary. The problem with this is that the MOSFETs' temperature coefficient is not constant and is a function of the source-drain current. Also, here the use of the source resistors in combination with the source-gate capacitors C9, C10, C13 and the RC networks R44, C11 and R45, C12 yields an output stage with maximum stability and long term reliability.

The RC network consisting of R46, R47 and C14 serves to ensure that the output stage has a load of high frequencies, again to ensure stability of the power amp output stage. Resistor R48 and R49, and capacitor C6, determine the gain of the power amp. The values shown set the overall voltage gain to 34 for frequencies within the audio passband. At higher frequencies the decreasing impedance of capacitor C6 applies an increasing amount of overall negative feedback, reducing the overall voltage gain.

aem project 6005

AEM6005 PARTS LIST

Semiconductors

Q1, Q2 ECG461 or equiv.
 Q3, Q4 BC639
 Q5 BC640
 Q6 BC557
 Q7 BC639
 Q8 BC547
 Q9 MJE350
 Q10, Q11, Q12 MJE340
 Q13-Q16 MJE350
 Q17, Q18 MJE340
 Q19, Q20 2SK134
 Q21, Q22 2SJ49
 D1-D6 1N914 or equiv.
 D7-D10 100 V/1 A
 fast recovery diodes.
 ZD1 12 V/400 mW zener
 ZD2-ZD5 12 V/1 W zeners

Resistors

all 0.25W, 5%
 unless noted

R1 100k
 R2 10R
 R3 1k
 R4, R5 220R
 R6, R7 22k, 1%
 R8 180R, 1%
 R9 3k3
 R10 10k, 1W
 R11 1k
 R12 2k7
 R13 120R, 1%
 R14 10k, 1W
 R15, R16 10R
 R17, R18 10k, 1W
 R19, R20 220R, 1%
 R21-R26 100R, 1%
 R27-R30 680R, 1%
 R31, R32 100R, 1%
 R33, R34 33R, 1%
 R35 100R
 R36-R39 270R
 R40-R43 0R22, 5W
 R44, R45 22R
 R46, R47 22R, 1W
 R48 33k
 R49 1k
 R50 not used
 R51-R54 10R
 RV1 20k
 RV2 200R

Capacitors

C1 470n MKP else MKT
 C2 1n MKP else MKT
 C3 47p ceramic
 C4, C5 100µ/63V RB electro
 C6 15p ceramic
 C7, C8 18p ceramic
 C9, C10 330p MKP
 else ceramic
 C11, C12 33p ceramic
 C13 220n MKP else MKT
 C14 22n MKP else MKT
 C15-C18 100µ/63V
 RB electro.
 C19, C20. 100n MKP else MKT

Miscellaneous

AEM6005 pc board; four TO3
 mounting kits; 10 TO126 (MJE)
 mounting kits; thermal paste;
 nuts and bolts; heatsink bracket,
 as specified; two nylon bolt insu-
 lators.

Estimated cost:
\$100-\$140

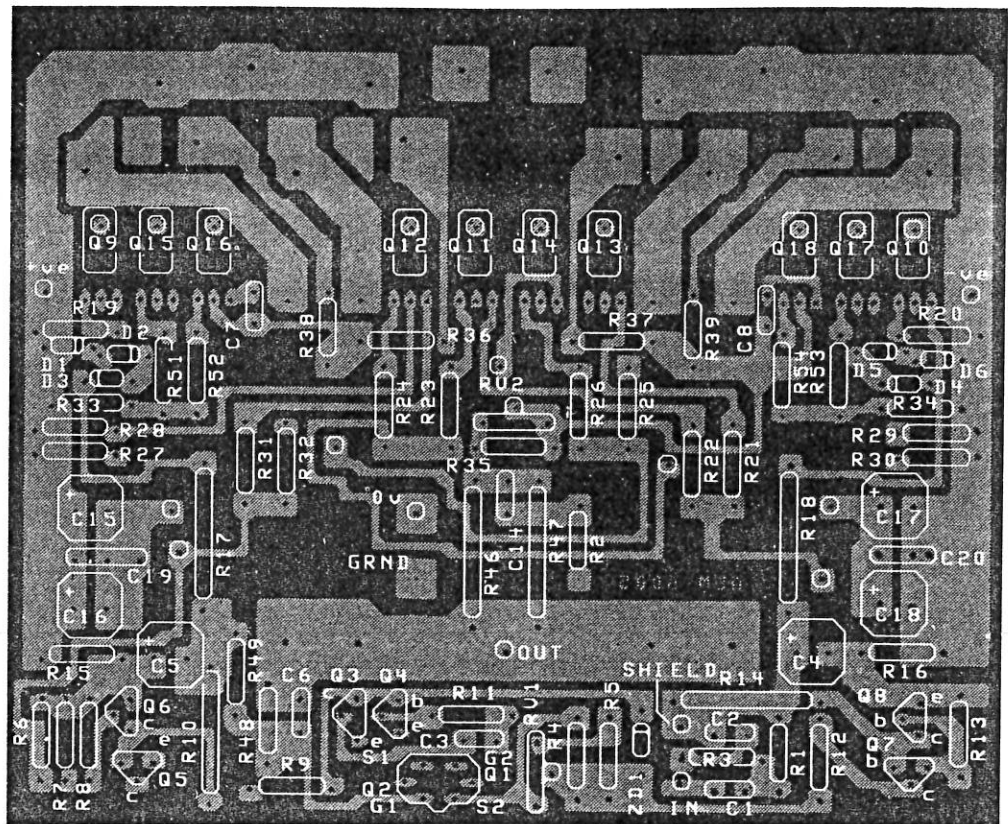

Topside component overlay

Rear view of the pc board, showing the rear side components.

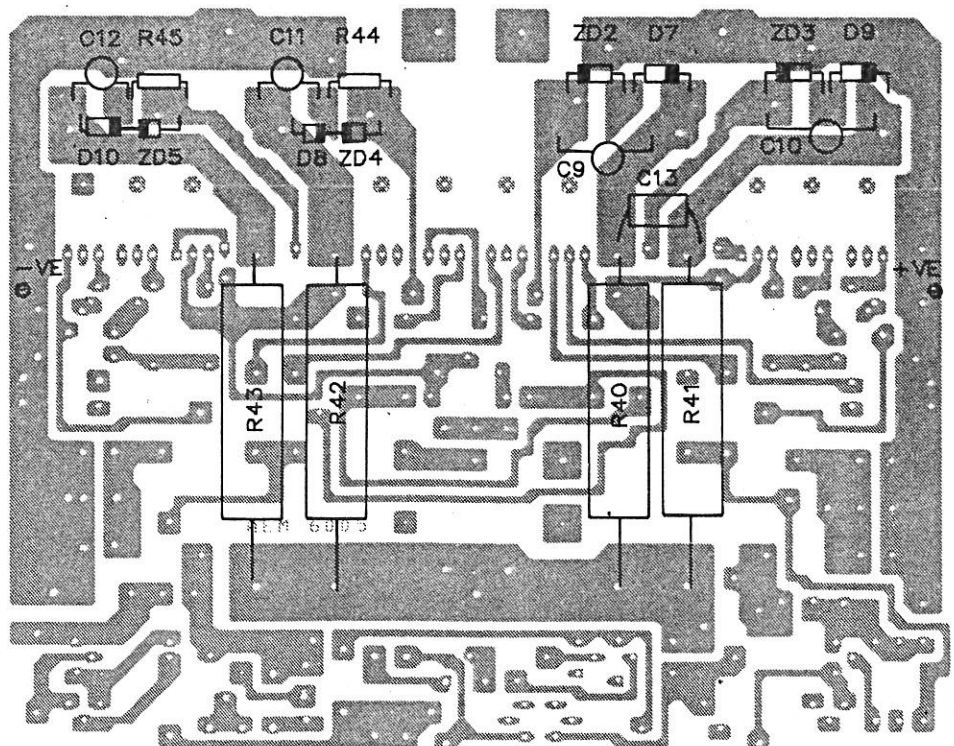

voltage gain stage which reduces distortion before the application of any overall negative feedback. In fact, for similar gains a differential symmetric circuit like this is at least an order of magnitude superior in its distortion performance over that of an asymmetric single transistor.

The input stage

The advantage of the fully symmetric differential pair over an asymmetric differential pair for large signal voltage levels has already been stated. However, in the case of the voltage amplifier the symmetric differential circuit is used to linearize the transfer characteristic of the voltage gain. The main differential pair at the front end of the power amplifier on the other hand has to perform a slightly different function to that of the voltage gain stage. It must act as a difference amplifier producing a signal at its output which is an accurate difference between the signals at each of its differential inputs. In this application the asymmetric differential pair is superior to the fully symmetric differential pair using the same bipolar transistors.

Another important aspect to the design of input differential pair is its ability to maintain the output dc offset of the power amplifier to a sufficiently low level. In most power amplifiers the gain at dc is reduced to unity by the introduction of a capacitor into the negative feedback loop. Of necessity, this capacitor usually must be an electrolytic type which can have a significant effect on the subjective performance of the power amplifier, particularly at low frequencies.

During the development of the AEM6000/AEM6005, a number of test amplifiers were constructed and auditioned. These tests revealed that this dc blocking capacitor tended to cause significant degradation of the subjective performance. In the development of these projects, it was decided to design the input stage with sufficient dc tracking capability so as to enable elimination of this dc blocking capacitor entirely. Accordingly, the input stage was designed using a highly-matched dual JFET, the NTE or ECG 461. This device is available from Stewart Electronics in Melbourne and although there are various alternatives available, this is the preferred device.

The final design for the input differential pair, as can be seen on the main circuit diagram, employs a cascode configuration using the dual JFET and a pair of bipolar transistors. The operating conditions for this cascode arrangement are determined by two constant current sources formed from transistors Q5, Q6, and Q7, Q8. The zener diode ZD1 ensures that the bases of transistors Q3 and Q4 are approximately 12 volts above the sources of the JFETs. In other words, the drain-source voltages of the input JFET are held constant at approximately 11.4 V. The advantage of the cascode pair such as in this circuit, is that it provides excellent isolation of the output of the differential pair from its inputs which provides a more linear and faster voltage amplifying stage. A more detailed description of the operation of the input pair is included in the Circuit Operation section of this article.

The asymmetric to symmetric converter

To convert from the asymmetric output of the input stage to the symmetric input required by the symmetric voltage amplifier stage and asymmetric to symmetric converter stage has been included. This stage consists simply of four bipolar transistors forming a symmetric differential amplifier fed from two constant current sources formed from Q9 and Q10.

The overall topology of the AEM6005 power amplifier module — that of an asymmetric cascode input stage followed by an asymmetric to symmetric converter, a fully differen-

tial symmetric voltage amplifier and a power MOSFET output stage — was found to provide the best subjective performance of the various topologies tried during development. The absence of a dc blocking capacitor in the feedback loop combined with high speed linear stages throughout and lower overall feedback than most MOSFET designs has yielded a power amplifier with exceptional subjective and objective performance.

Construction

In this part we are discussing the AEM6005 module. Details of assembling the modules into a chassis with a power supply will be described in Part 2 of this article. Construction is not difficult due to the fact that the modules are based on the AEM6005 printed circuit board, the artwork of which is published elsewhere in this article. However, when dealing with power amplifiers, care should be taken even with the smallest task.

Commence by preparing the heatsink bracket which is fashioned from a length of L-shaped aluminium extrusion. The drilling details for this bracket are shown elsewhere in this article. If using the 6005 module to incorporate into the 5000 power amplifier, a new bracket will be required as discussed earlier. On completion of the bracket, be sure to check and clear all the holes of burrs that may damage insulating washers used with the devices bolted to the heatsink.

The MOSFETs should be the first components positioned as some manoeuvring may be necessary which would put undue stress on any other components already positioned. Mount the MOSFETs as shown in Figure 3 with the leads through the bracket and pc board ensuring to insulate the leads from the bracket. Insulating washers with a smearing of thermal paste must be used between the MOSFETs and the bracket as the case of the device is connected internally to the source of the MOSFET which will be shorted to the bracket if not correctly insulated.

The four mounting bolts which are closest to the pc board are used to connect the sources of the MOSFETs to the rest of the circuitry. Therefore, it is essential that these bolts make good electrical contact between both the case of MOSFETs and the track of the pc board. It is also essential to use spaghetti or some other type of insulating material to stop the bolt from shorting to the heatsink bracket. The other four mounting bolts must be insulated from the pc board, bracket and MOSFETs. The simplest method by which to do this is to use nylon nuts and bolts, although care should be taken when using these not to over tighten them and possibly strip the thread from the bolts. Once the MOSFETs have been mounted in position, use a continuity meter to test for any shorts between the MOSFET cases and the heatsink bracket. ▶

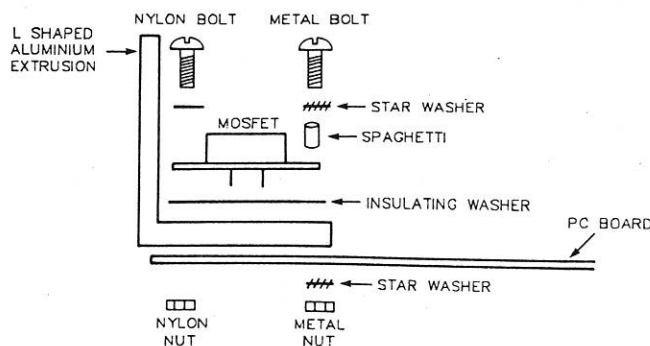

Figure 3. How the heatsink bracket and MOSFETs are mounted to the pc board.

aem project 6005

The next components to be positioned should be those on the copper side of the pc board. Be careful to follow the component overlay so as not to confuse their positioning. Several of these components need to be soldered across adjacent tracks so care should be taken to avoid these leads shortening.

Once you have finished this stage, the rest of the pc board can follow. Begin with the passive components such as the resistors and feedthrough links. The feedthrough links are marked on the overlay, so check to ensure that they have all been completed before proceeding. Next, you should position the smaller capacitors as their physical size may interfere with the construction of the rest of the pc board. The diodes, including the zeners, can be soldered into position. These are the first components, other than the MOSFETs, that need to be oriented according to polarity so as to avoid possible damage. To verify their positioning, refer to the component overlay.

Next to be positioned should be the active components. The bipolar transistors, including the MJE350s and 340s, and dual JFET all must be positioned according to polarity so it is essential to follow the overlay precisely. Take great care not to confuse the transistors and this will almost surely result in damage. When mounting the MJE devices you will need to use insulating washers so as not to short the case on the rear side to the heatsink bracket. The rear of the transistor is connected internally to the collector of the transistor. Thermal paste, as used with the MOSFETs, should also be used between the transistors and the heatsink which is essential to the efficiency of the heatsink to reduce the temperature of the transistors. When you have positioned these components check the mounting bolts on the copper side of the pc

board to see that they are not shorting to any of the adjacent tracks.

Once you have finally bolted the transistors in, it is wise to check with a continuity meter that the collector is not shorted to the heatsink bracket. This is essential because, if any burrs are remaining on the heatsink bracket they may pierce the insulating washer and hence short the collector to the chassis via the bracket. There is no need to insulate the bolts from the MJE's as they are self insulating.

Finally, it is time to position the larger capacitors and preset potentiometers. The larger capacitors are all electrolytic types and therefore need to be positioned the right way round. If positioned incorrectly a breakdown of the dielectric inside the capacitor will most surely occur at first switch-on. When positioning the presets you will need to be careful of the tracks running beneath them as some presets are not insulated at this point. Sit them slightly proud of the board surface.

The remaining four 5 W/OR22 resistors were placed on the rear side of the pc board due to lack of space on the top side. This was done for compatibility of the 6005 module with the 5000 chassis. When positioning these, be sure to space them a couple of millimetres from the board so as to avoid unnecessary heating to the board after prolonged use.

The 6005 module should now be complete. However, you should do a thorough check of the pc board for any unwanted solder bridges between adjacent tracks. Also be sure to check the top side of the board for any of the component's leads shorting to tracks. A final check of the orientation of all components and topside solder joints should be undertaken before first powering-up your module. 

AEM Printed Circuit Service

NEW BOARDS IN STOCK FOR RECENT PROJECTS

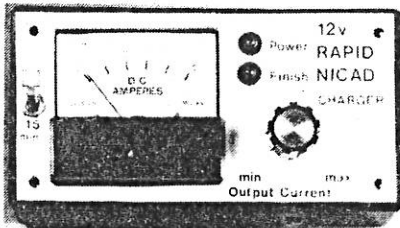

9503 NICAD CHARGER FOR R/C MODELS

Featured in our December '86 issue, this project will fast-charge NiCad battery packs from 12-14 Vdc. Requires only common parts.

\$9.35

6506 WORKHORSE POWER AMP

Delivers 100 W into 4 ohms, 50 W into 8 ohms. Rugged design is simple, cheap to build. Uses only common parts. (Jan. '87).

\$17.64

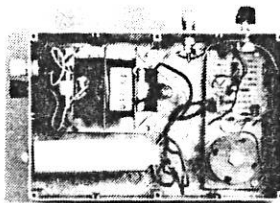

9502 ELECTRIC FENCE

Project features variable output voltage, simple construction, all parts readily available, (Described Oct./Nov. '86) **\$11.40**



2510 WORKBENCH POWER SUPPLY

Project is a general purpose variable power supply. Delivers 2 A across output range of 3.5-25 volts. Fully protected, 200 mA/2 A current limit. (Described Feb. '87). **\$21.25**



2502 LOGIC/DATA PROBE

Essential fault-finding tool for hardware, hackers and digitologists. Simple, cheap, uses all common parts.

(Described Jan. '87). **\$8.95**

Copies of the relevant articles cost \$4.00 each post-paid.

Order pc boards by the project number and title. We do not stock complete kits or components. Send orders to:

Australian Electronics Monthly
PO Box 289, WAHROONGA 2076 NSW
(02) 487 2700.

PLEDGE YOUR PLASTIC!
Bankcard, Mastercard,
Visa & American Express
accepted.

PAY BY PAPER!
Cheques or money orders OK.
Make them payable to
"Australian Electronics Monthly".

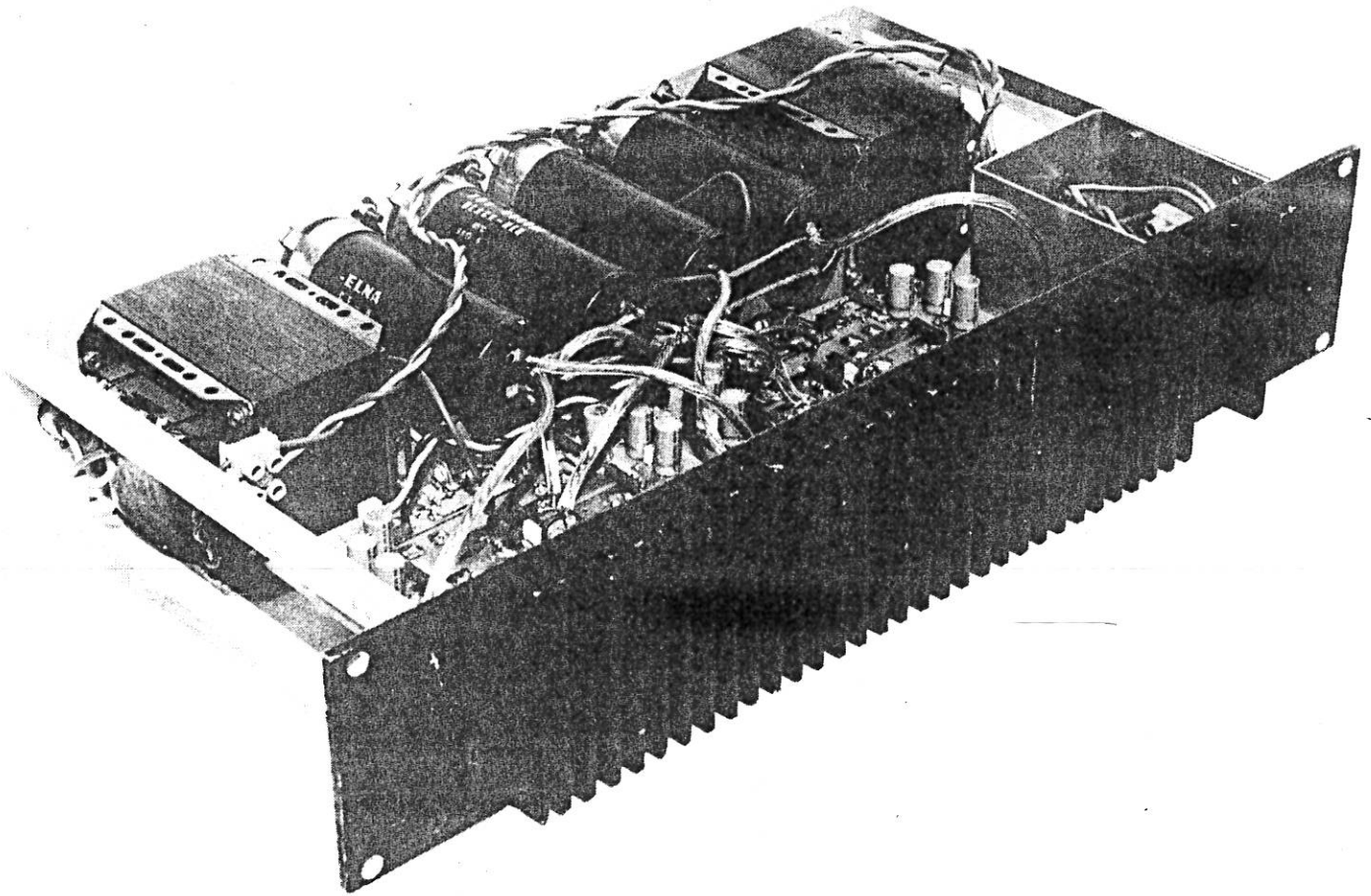

Upgrade your Series 5000 with the AEM6005 100W 'U-F' topology amp module

David Tilbrook
Technical Systems Australia

The 6005 module, described in Part 1, is ideal for upgrading David Tilbrook's now legendary Series 5000 stereo power amp. This article details how it's done and discusses new power supply arrangements.

THE 6005 MODULE has been designed to fit the Series 5000 chassis, providing a relatively simple upgrade and a significant improvement in performance.

Begin the upgrade process by preparing a new heatsink bracket. This is required to accommodate the extra components mounted to it. The complete drilling details of the bracket are published elsewhere in this article. The bracket has been designed to bolt directly to the series 5000 heatsink so as to minimise the need for extra drilling to your front panel. The dimensions shown for the bolt holes used to mount the bracket to the heatsink are for those heatsinks drilled to take bolts through the front, between the fins. Some producers made heatsinks which were drilled and tapped from the rear, which displaces the holes 5-6 mm. Check your heatsink and mark out and drill the new bracket accordingly.

The AEM6005 modules use the same power MOSFETs as were employed in the Series 5000, so these can be removed from your existing 5000 modules if you are doing the upgrade. In this case, care should be taken when removing the MOSFETs from the 5000 pc boards so as not to damage the drain and gate leads. Avoid applying too much heat to these leads so that the risk of damage to the devices is minimised. Use a solder sucker or solder wick to remove all of the solder applied to these leads before attempting to lift the devices from the 5000 pc board.

When mounting the MOSFETs onto the 6005 board, follow the mounting procedure shown in Part 1, Figure 3. The MOSFETs, when mounted in the 6005 modules, need to be secured with insulated bolts and nuts (as shown in Part 1, Figure 3). These insulated bolts are essential so as to avoid shorting

Front, half-angle view of the upgraded 5000, now the AEM6005, without chassis covers. The "Monster Cable" employed in the power supply wiring is clearly visible.

the case of the devices to the copper tracks on the underside of the boards.

As described in Part 1, the modules are nearly the same size as the boards used in the 5000 power amplifier and hence can be mounted in place of the previous modules. Before you finally mount the newly prepared bracket and 6005 modules into the chassis it is a wise precaution to power up the modules to check that all is well. The quiescent current and dc offset presets should be adjusted at this stage as this procedure becomes substantially more difficult once the mounting has been completed. This is of particular importance when dealing with the dc offset potentiometer RV1, as it will be difficult to reach.

First power-up

When powering-up your modules for the first time you should connect a 10 ohm, 1W resistor in series with each rail. Do not connect the load at this stage. This simple procedure will prevent most faults within the power amp from causing serious damage. The 10 ohm resistors limit the maximum current that can flow into the modules in the event of a fault condition. Any fault that results in excessive current consumption module will cause the resistors to burn out. If this occurs you must locate the fault before applying power to the modules without the 10 ohm resistors in circuit. Although you can go through quite a number of resistors this way it is definitely preferable to the option of damaging the output devices or pc board!

The 10 ohm resistor in series with the positive rail can also be used to adjust the quiescent current. Connect your multimeter to measure the voltage across this resistor by attaching

the leads to either side of the resistor and, with power applied, adjusting RV2 until your meter reads 2 Vdc. This should ensure that the correct amount of bias current is flowing through the MOSFET output stage. Run the module in this condition for about 15 minutes and check the heatsink temperature. If the heatsink runs excessively hot (i.e. more than around 40 degrees Celcius), then try decreasing the quiescent current slightly.

The dc offset adjustment may be slightly more complex. It was discovered during the development of the 6005 modules that in some circumstances, depending upon the tolerances of the components, that the correct setting of the dc can be difficult. The preset potentiometer has been configured in such a way that it provides a non-linear amount of adjustment. The preset provides a fine adjustment around its centre position becoming increasing coarse as it is adjusted further from this position.

If component tolerances require this preset to be set near either extreme, the correct setting will be very difficult to make. To correct this imbalance it is necessary to adjust the values of one of the resistors R4 and R5. As specified, they are 220R. However, the value of one of these may have to change slightly to return the preset to a position closer to its centre. This can be done by beginning with a 1k resistor in parallel with R4 or R5 while measuring the voltage between the power amp output and ground. Experiment with different values until the dc on the output is a minimum with the preset set at its centre position. Once you have found the optimum value of resistor that gives the majority of the vernier of the preset around the centre, then you can adjust the preset to give as close to zero dc offset as the preset will allow.

Using this system, you should be able to adjust the offset as low as $\pm 10\text{-}20\text{ mV}$. Allow the module time to heat up before

Topside view inside the unit, showing the general layout and supply wiring to the boards.

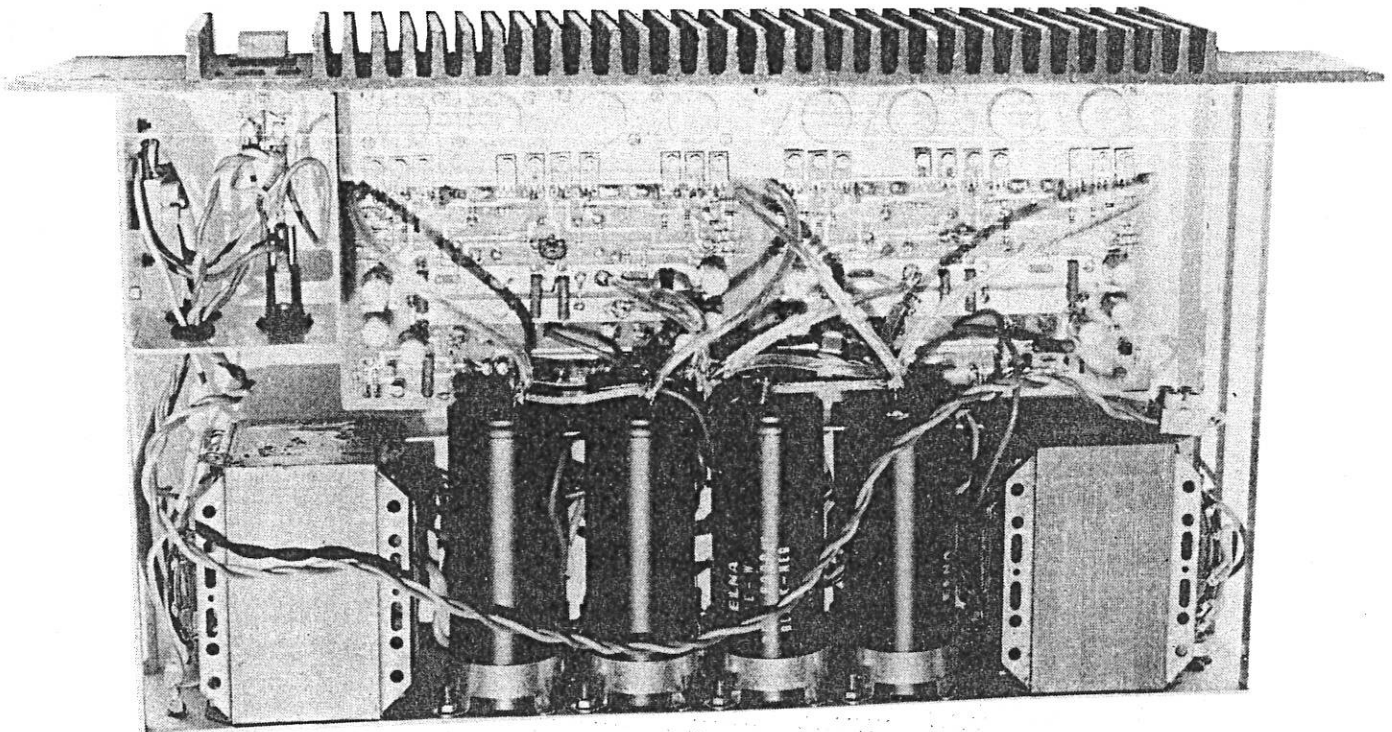

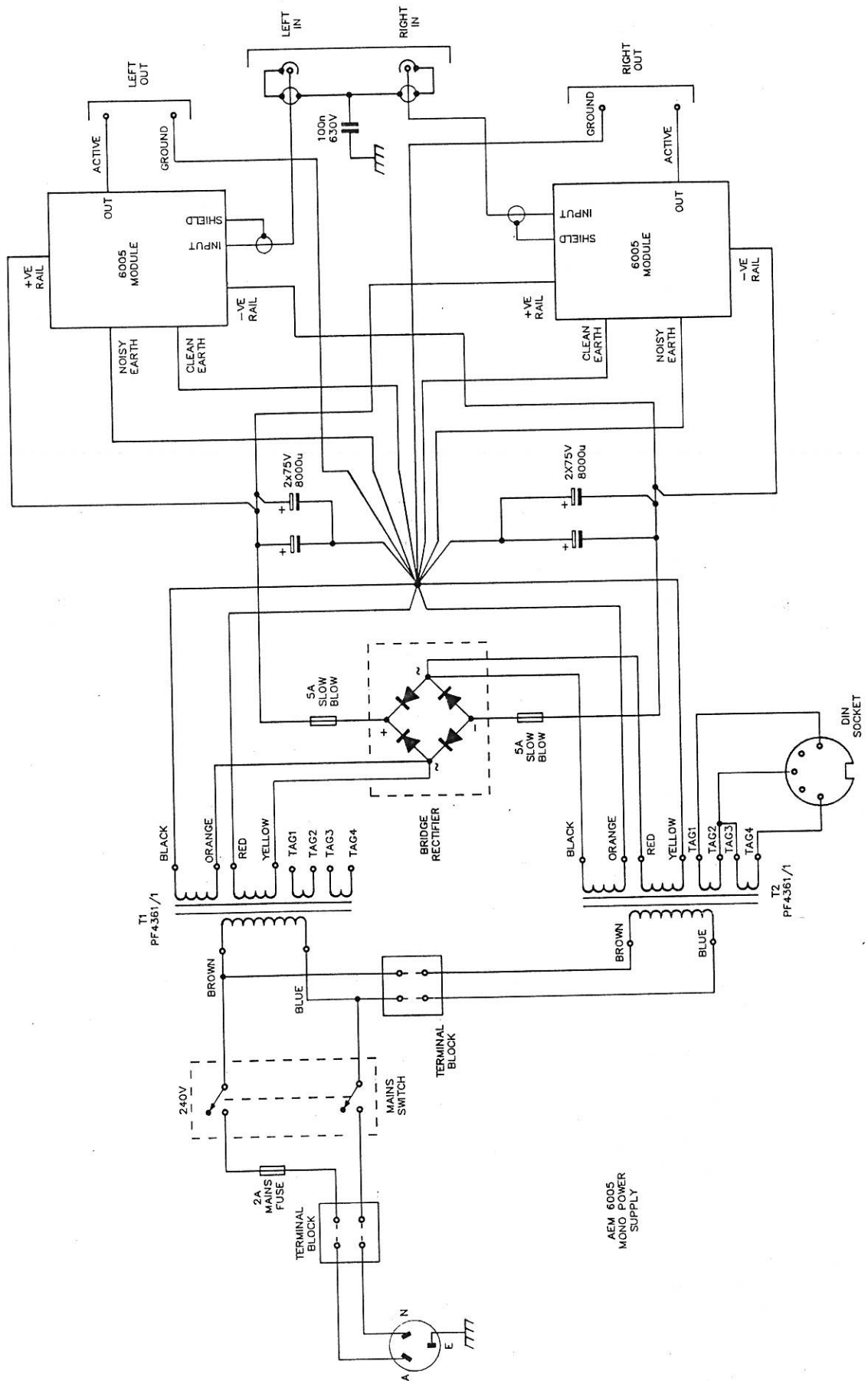

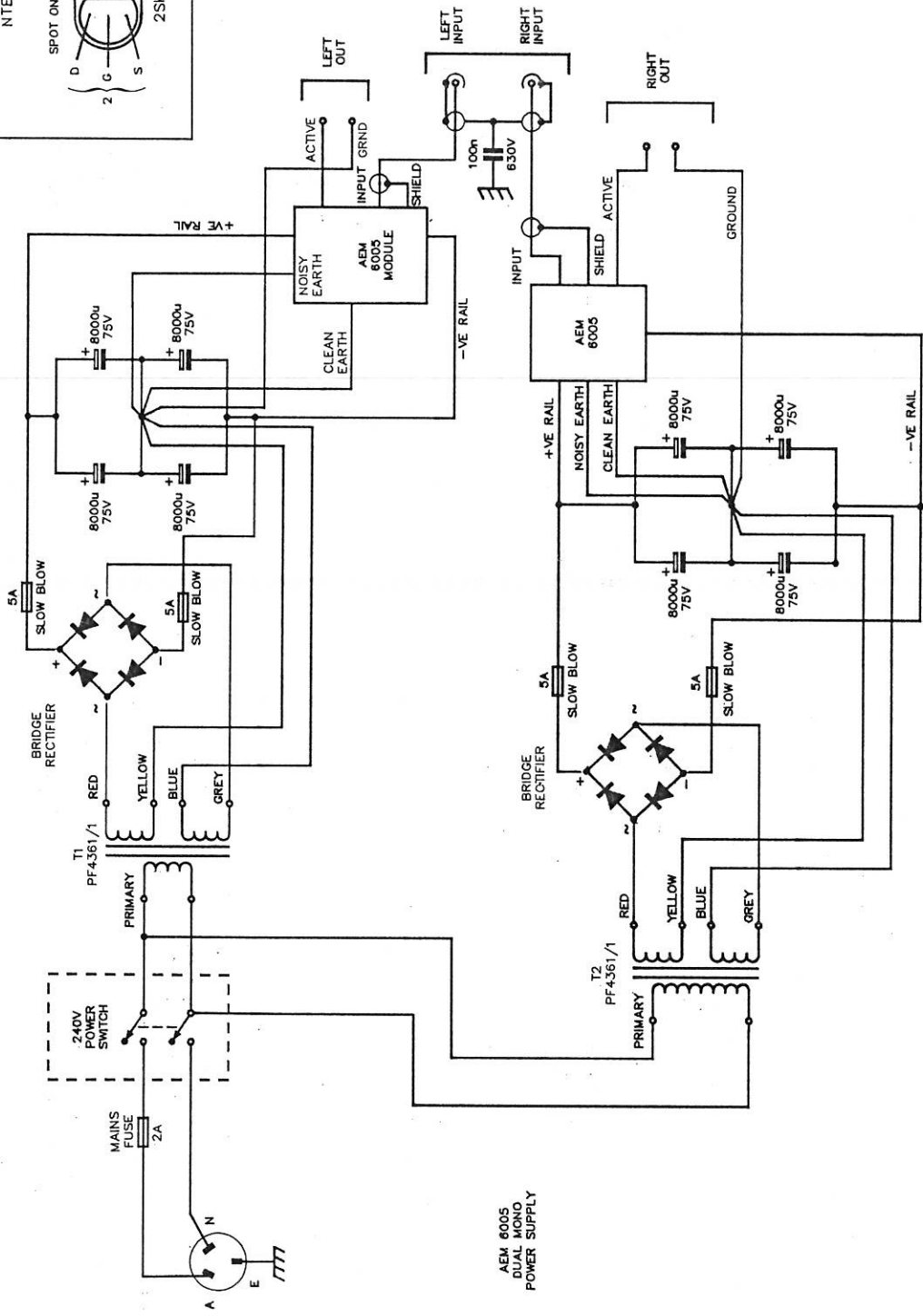
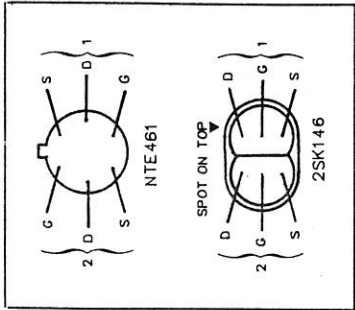

AEM 6005
DUAL MONO
POWER SUPPLY

aem project 6005

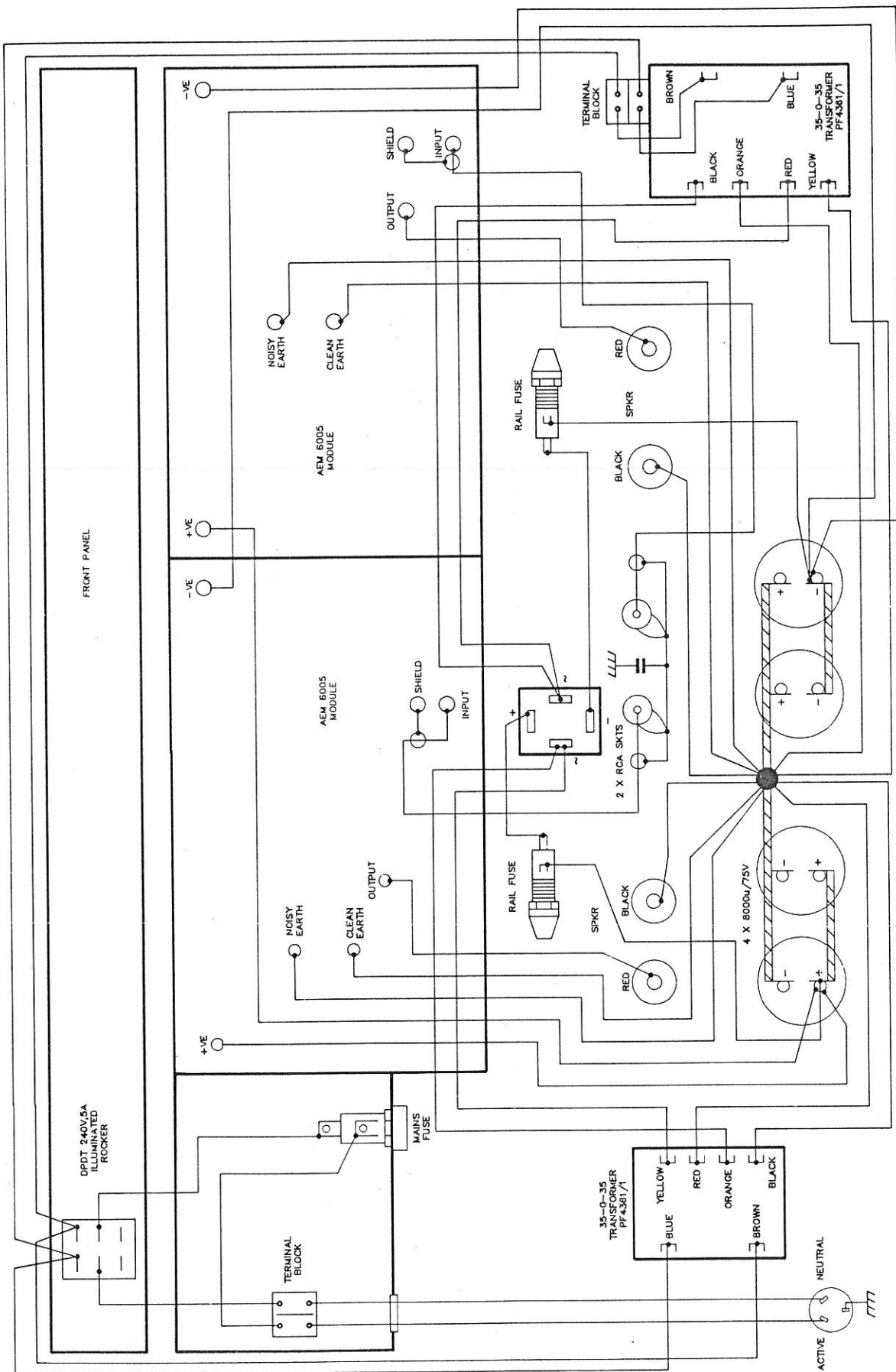

finalising setting of the preset potentiometer as the dc offset tends to drift whilst warming up.

Module mounting and wiring

Once you have completed the mounting of the modules onto the heatsink bracket, you can mount the bracket into the chassis, bolting it on the front panel heatsink. Before doing this, however, be sure to have drilled out the holes on the pc board for the input, output and rail wiring to suit the wire used. The supply rail wires will need to be of substantial size to ensure the best performance and we employed "Monster Cable".

Before actually mounting the modules, it is wise to wire the input into position on the board as this also becomes more difficult after mounting has been completed. Use shielded cable to wire the input as these wires will have to pass fairly close to transformers. Hum is injected into the input wiring simply by its physical proximity to the transformers, so experiment with the location of this wiring if you experience any difficulty with hum. The hum performance of the upgraded unit is extremely good and was achieved with no difficulty.

Once the module has been readied it can be secured to the heatsink, making sure to use a generous amount of thermal paste between the bracket and the front panel heatsink to ensure good thermal contact between them.

The modules should now be securely in position and the rest of the wiring can be completed. One aspect which will need to be looked at, whether you are mounting these modules into your old 5000 or into a completely new chassis, is that of the fusing. The fusing is the last line of defense for your modules in the case of a fault, so it is imperative that the rail fuses not be left out. In the case of the Series 5000 these fuses were incorporated onto the pc board. This has not been done in the AEM6005 module since it can introduce significant resistance in series with the power supply to the MOSFETs which can cause some degradation in overall performance.

The transient performance of a power amp is greatly affected by the capacity of the power supply to deliver current quickly to the output devices. It is for this reason that heavy gauge cables are specified for the rail and output connections. Incorporation of supply fuses into the supply line introduces both resistance and inductance which is not desirable. Instead, fuses are fitted between the output of the bridge rectifier and the main filter capacitors. As seen in the parts list, we recommend the use of 3AG 5A slow blow fuses. The slow blow types are necessary because of the surge current that occurs at the moment of turn on due to the charging of the

Underside view inside the unit. Note the two power supply fuse holders either side of the bridge rectifier which is mounted on an aluminium plate running between the two mains transformers. The mains fuse is seen in the enclosure at top right.

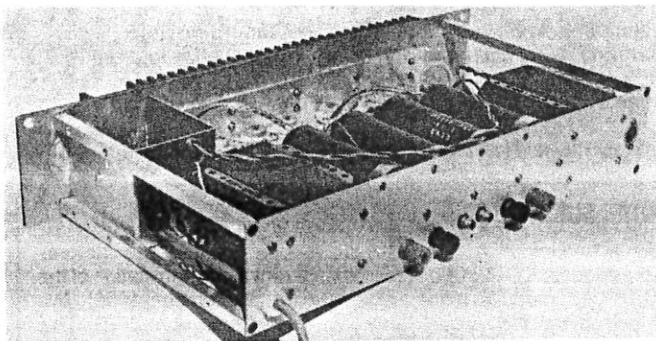
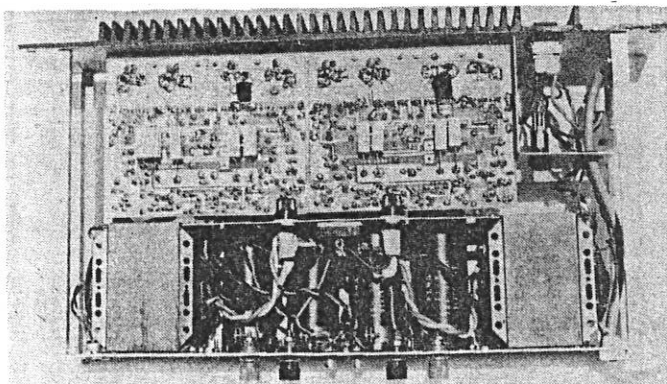

Rear, half-angle view of the unit, showing the connectors mounted on the rear panel. The two input RCA sockets are between the two pairs of speaker terminals, while the DIN socket at upper right provides low voltage ac output for accessories. The mains cord enters via a grommet at bottom left.

main electrolytic capacitors. At the instant of turn on these capacitors represent a short circuit and the resulting huge current surge will blow normal 5 A fuses. The slow blow type will not blow unless the excessive amount of current continues. In the prototype unit these fuses are mounted with 3AG fuse holders which are mounted to the bracket within the 5000 chassis used to secure the bridge rectifier.

Once the fusing is complete you should wire the earth and rail wires. It is essential to ensure that the rails are wired correctly. Check the filter capacitors to see which is the positive, negative and earth and connect these points to their respective positions on the modules according to the component overlay published in Part 1. The earthing arrangement for the 6005 module is just as imperative as it was for the 6000 power amp modules. There are two earth areas on the pc board which need to be connected to the centre point of the filter capacitors. This is to ensure that the clean signal earth is clearly separated from the noisy power supply earth. If this is not done the module will still operate, although with hum and noise figures orders of magnitude worse than those published. The output should be wired directly from the pc board with the black output terminal connected directly to the centre point of the main electrolytic filter capacitors.

If you are upgrading the Series 5000 the same power supply can be used with the exception of the changes to the power supply fusing which has already been discussed. We have ▶

AEM6005 PARTS LIST

- 2 x AEM6005 modules;
- 1 x heatsink bracket;
- 1 x Series 5000 heatsink and chassis;
- 4 x 8000u/75 V electrolytics;
- 2 x PF4361/1 transformers;
- 1 x 100n/630 V metallised film capacitor.
- 1 x 240 Vac DPDT illuminated rocker switch;
- 2 x red binding posts;
- 2 x black binding posts;
- 4 x earth lugs;
- 2 x RCA sockets;
- 1 x PB40 bridge rectifier;
- 2 x 5A 3AG slow blow fuses;
- 3 x 3AG chassis-mount fuse holders;
- 2 x 2-way terminal blocks;
- Two metres of heavy gauge hookup wire of at least 32 x 0.2 mm, or "Monster Cable", for power supply wiring;
- Mains cable, plug and clamp grommet.

Drilling details for the heatsink bracket. Mounting hole positions shown in the upright piece were taken from the original 5000 heatsink which located the mounting bolts between the fins. Later heatsink designs have tapped holes positioned behind the fins which necessitate slightly different hole positions. These should be measured from your unit.

NOTE: SUBSTITUTE DUAL JFET INPUT DEVICES

Some incompatibilities between various input stage devices employed for Q1-Q2 have become apparent since publication of the AEM6000 module (June, July, August September 1986). We specified the NTE461, a New Tone Electronics dual JFET. This device is important to the overall performance of the 6000 and 6005 modules. Some suppliers have substituted alternative devices which some constructors have raised questions about.

The Philips BFQ10 can be used in the circuit instead of the NTE device without any difficulties. The 2SK146 dual JFET will operate in the circuit but has a different pinout and is therefore difficult to mount. We understand that the NTE device is available from Stewart Electronics in Melbourne. The pinout of all these devices, NTE461, Philips BFQ10, and the 2SK146 have been shown elsewhere in this article to clear all such confusion.

also included a diagram for a dual mono power supply for those wishing to employ it. This power supply can be incorporated within the 5000 chassis with the addition of a second bridge rectifier. The 5000 power supply is a single supply which is used for both modules. The dual mono configuration enables the power amp to become two mono power amps in the same box which is said to have superior channel separation compared to the mono supply.

To wire up the dual mono supply, follow the circuit diagram closely to ensure correctness. We have decided not to include drilling details of a new chassis and leave it to the enthusiast who may wish to experiment. Be careful to check the orientation of your electrolytics and bridge rectifiers when following the circuit diagram, along with the wiring of the transformers, as damage will occur if these are incorrect.

Pay particular attention to all of the 240 volt wiring. Ensure that all terminations and solder joints have been securely made. It is essential to be aware that any shorts in the 240 V wiring will cause damage.

Hold breath . . . and switch on

With your wiring completed, before powering-up you should recheck the wiring and run through the amplifier with a continuity meter to ensure all is well.

Power-up the amp. If all is well, then leave the amp to warm up. This is necessary to allow time for the amp to stabilize before any adjustments are made. Set your multimeter on dc volts and connect it to the output of each channel in turn to ensure no dc offset has been disturbed before connecting your loudspeaker. If there is a dc offset, then use an insulated screwdriver to adjust the preset RV1. Finally, before connecting the 6005 to your loudspeakers, you should switch the amp on and off a few times to ensure all is well.

LEVEL

We expect that constructors of an **INTERMEDIATE** level, between beginners and experienced persons, should be able to successfully complete this project.

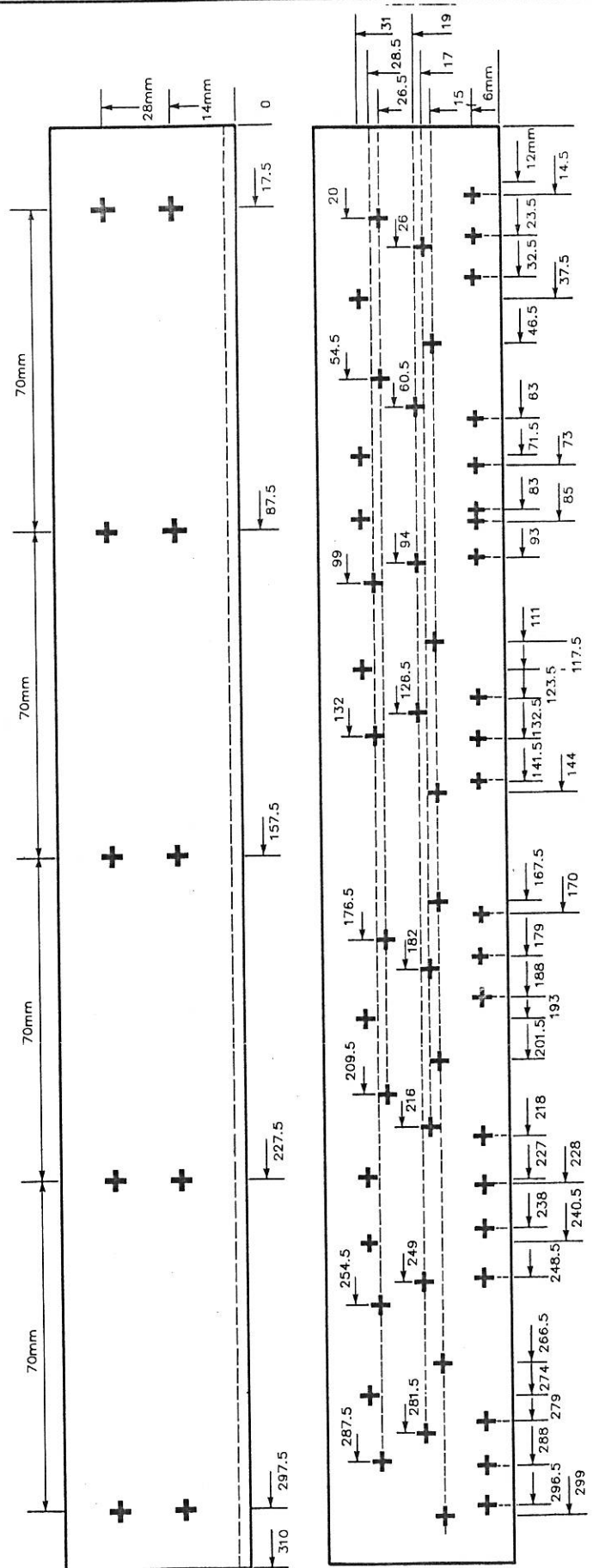

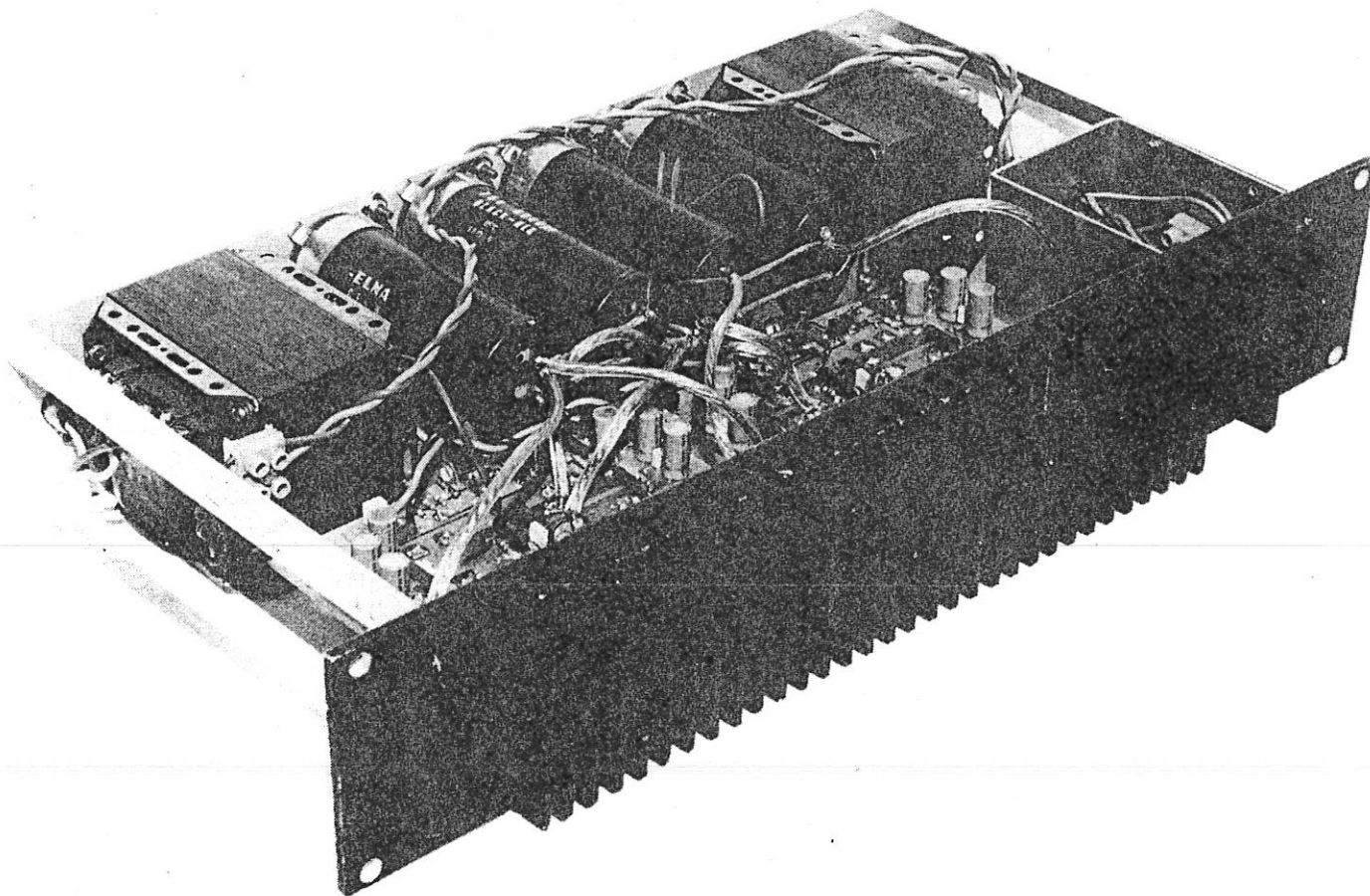

Upgrade your Series 5000 with the AEM6005 100W 'U-F' topology amp module

David Tilbrook
Technical Systems Australia

The 6005 module, described in Part 1, is ideal for upgrading David Tilbrook's now legendary Series 5000 stereo power amp. This article details how it's done and discusses new power supply arrangements.

THE 6005 MODULE has been designed to fit the Series 5000 chassis, providing a relatively simple upgrade and a significant improvement in performance.

Begin the upgrade process by preparing a new heatsink bracket. This is required to accommodate the extra components mounted to it. The complete drilling details of the bracket are published elsewhere in this article. The bracket has been designed to bolt directly to the series 5000 heatsink so as to minimise the need for extra drilling to your front panel. The dimensions shown for the bolt holes used to mount the bracket to the heatsink are for those heatsinks drilled to take bolts through the front, between the fins. Some producers made heatsinks which were drilled and tapped from the rear, which displaces the holes 5-6 mm. Check your heatsink and mark out and drill the new bracket accordingly.

The AEM6005 modules use the same power MOSFETs as were employed in the Series 5000, so these can be removed from your existing 5000 modules if you are doing the upgrade. In this case, care should be taken when removing the MOSFETs from the 5000 pc boards so as not to damage the drain and gate leads. Avoid applying too much heat to these leads so that the risk of damage to the devices is minimised. Use a solder sucker or solder wick to remove all of the solder applied to these leads before attempting to lift the devices from the 5000 pc board.

When mounting the MOSFETs onto the 6005 board, follow the mounting procedure shown in Part 1, Figure 3. The MOSFETs, when mounted in the 6005 modules, need to be secured with insulated bolts and nuts (as shown in Part 1, Figure 3). These insulated bolts are essential so as to avoid shorting

Front, half-angle view of the upgraded 5000, now the AEM6005, without chassis covers. The "Monster Cable" employed in the power supply wiring is clearly visible.

the case of the devices to the copper tracks on the underside of the boards.

As described in Part 1, the modules are nearly the same size as the boards used in the 5000 power amplifier and hence can be mounted in place of the previous modules. Before you finally mount the newly prepared bracket and 6005 modules into the chassis it is a wise precaution to power up the modules to check that all is well. The quiescent current and dc offset presets should be adjusted at this stage as this procedure becomes substantially more difficult once the mounting has been completed. This is of particular importance when dealing with the dc offset potentiometer RV1, as it will be difficult to reach.

First power-up

When powering-up your modules for the first time you should connect a 10 ohm, 1W resistor in series with each rail. Do not connect the load at this stage. This simple procedure will prevent most faults within the power amp from causing serious damage. The 10 ohm resistors limit the maximum current that can flow into the modules in the event of a fault condition. Any fault that results in excessive current consumption module will cause the resistors to burn out. If this occurs you must locate the fault before applying power to the modules without the 10 ohm resistors in circuit. Although you can go through quite a number of resistors this way it is definitely preferable to the option of damaging the output devices or pc board!

The 10 ohm resistor in series with the positive rail can also be used to adjust the quiescent current. Connect your multimeter to measure the voltage across this resistor by attaching

Topside view inside the unit, showing the general layout and supply wiring to the boards.

the leads to either side of the resistor and, with power applied, adjusting RV2 until your meter reads 2 Vdc. This should ensure that the correct amount of bias current is flowing through the MOSFET output stage. Run the module in this condition for about 15 minutes and check the heatsink temperature. If the heatsink runs excessively hot (i.e. more than around 40 degrees Celcius), then try decreasing the quiescent current slightly.

The dc offset adjustment may be slightly more complex. It was discovered during the development of the 6005 modules that in some circumstances, depending upon the tolerances of the components, that the correct setting of the dc can be difficult. The preset potentiometer has been configured in such a way that it provides a non-linear amount of adjustment. The preset provides a fine adjustment around its centre position becoming increasing coarse as it is adjusted further from this position.

If component tolerances require this preset to be set near either extreme, the correct setting will be very difficult to make. To correct this imbalance it is necessary to adjust the values of one of the resistors R4 and R5. As specified, they are 220R. However, the value of one of these may have to change slightly to return the preset to a position closer to its centre. This can be done by beginning with a 1k resistor in parallel with R4 or R5 while measuring the voltage between the power amp output and ground. Experiment with different values until the dc on the output is a minimum with the preset set at its centre position. Once you have found the optimum value of resistor that gives the majority of the vernier of the preset around the centre, then you can adjust the preset to give as close to zero dc offset as the preset will allow.

Using this system, you should be able to adjust the offset as low as $\pm 10\text{-}20$ mV. Allow the module time to heat up before

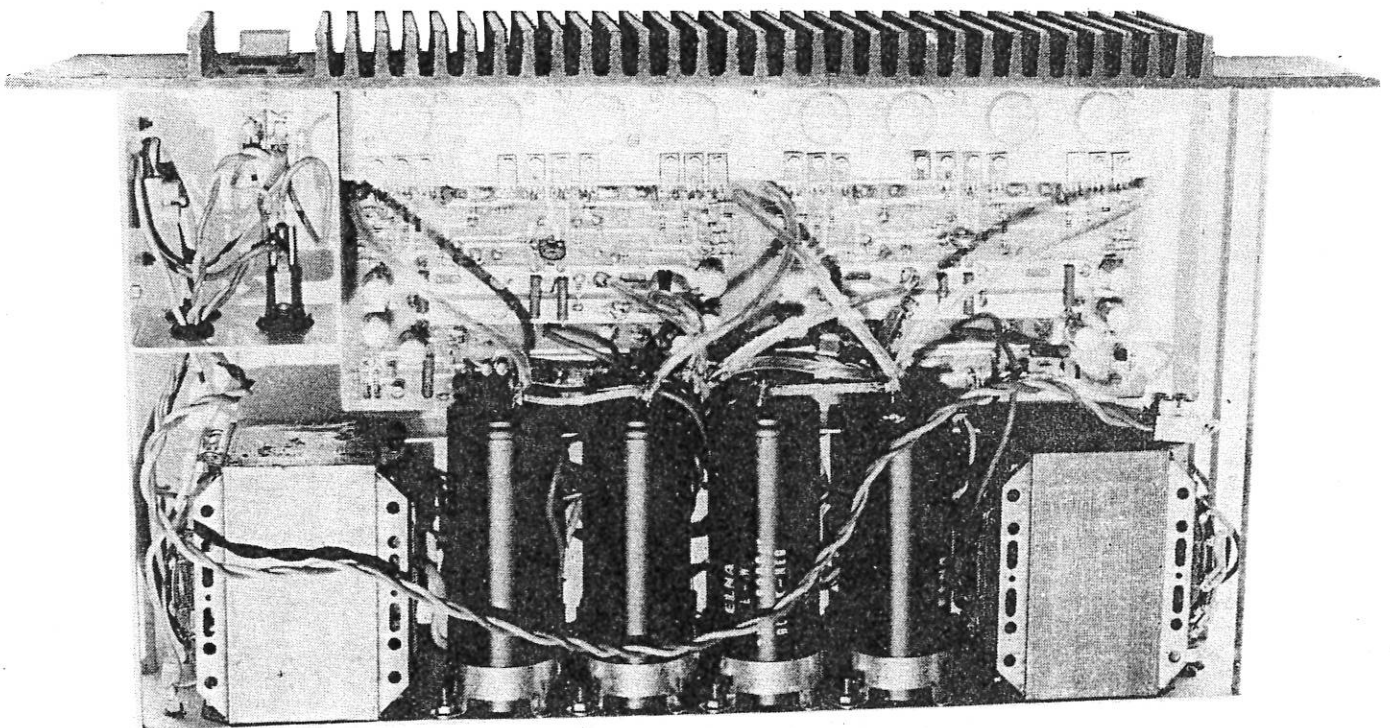

aem project 6005

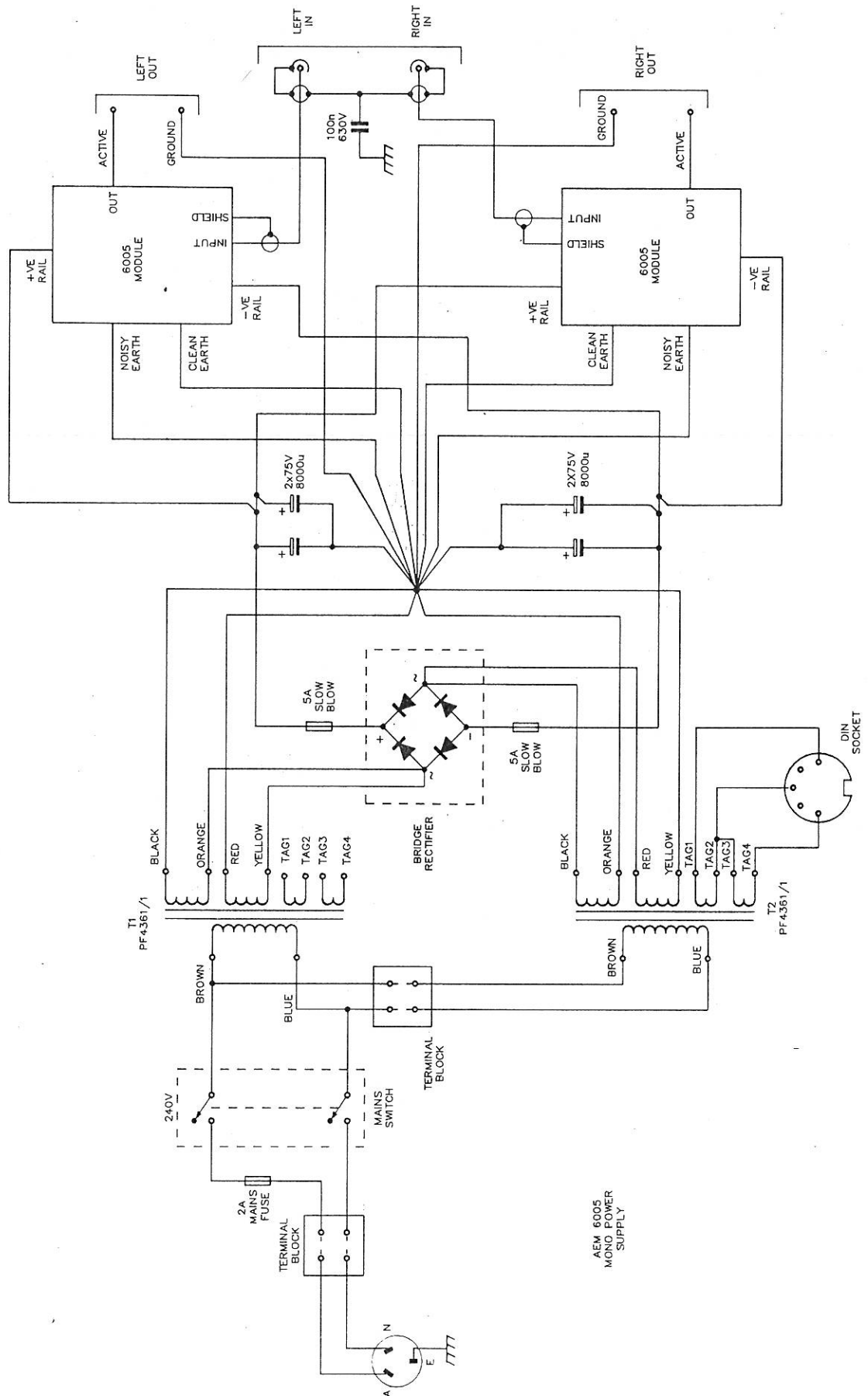

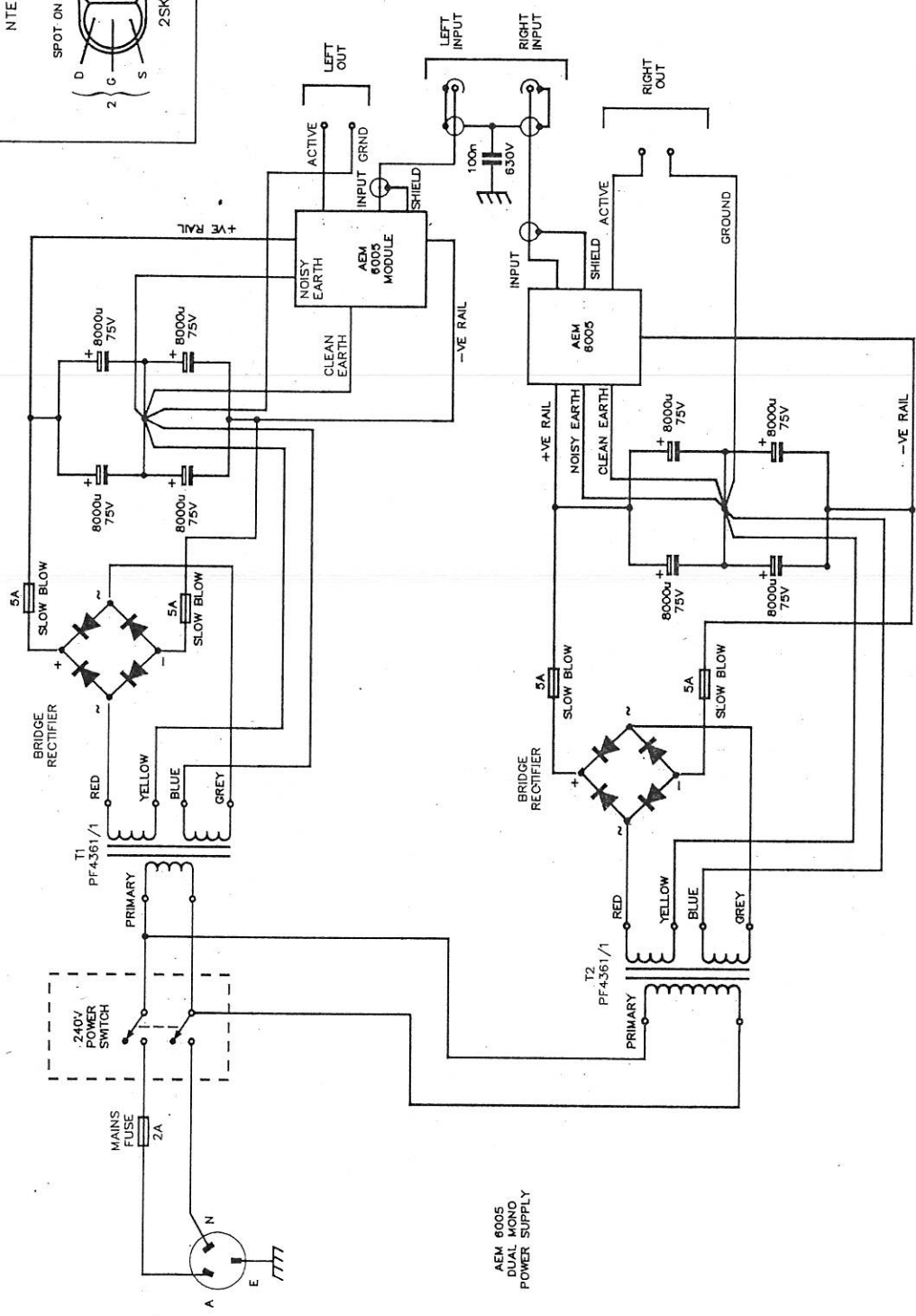
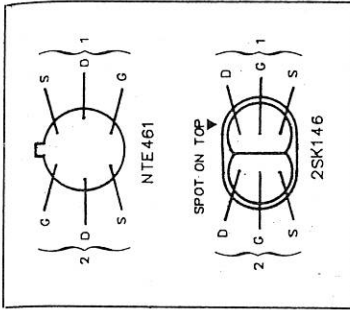

AEM 6005
DUAL MONO
POWER SUPPLY

aem project 6005

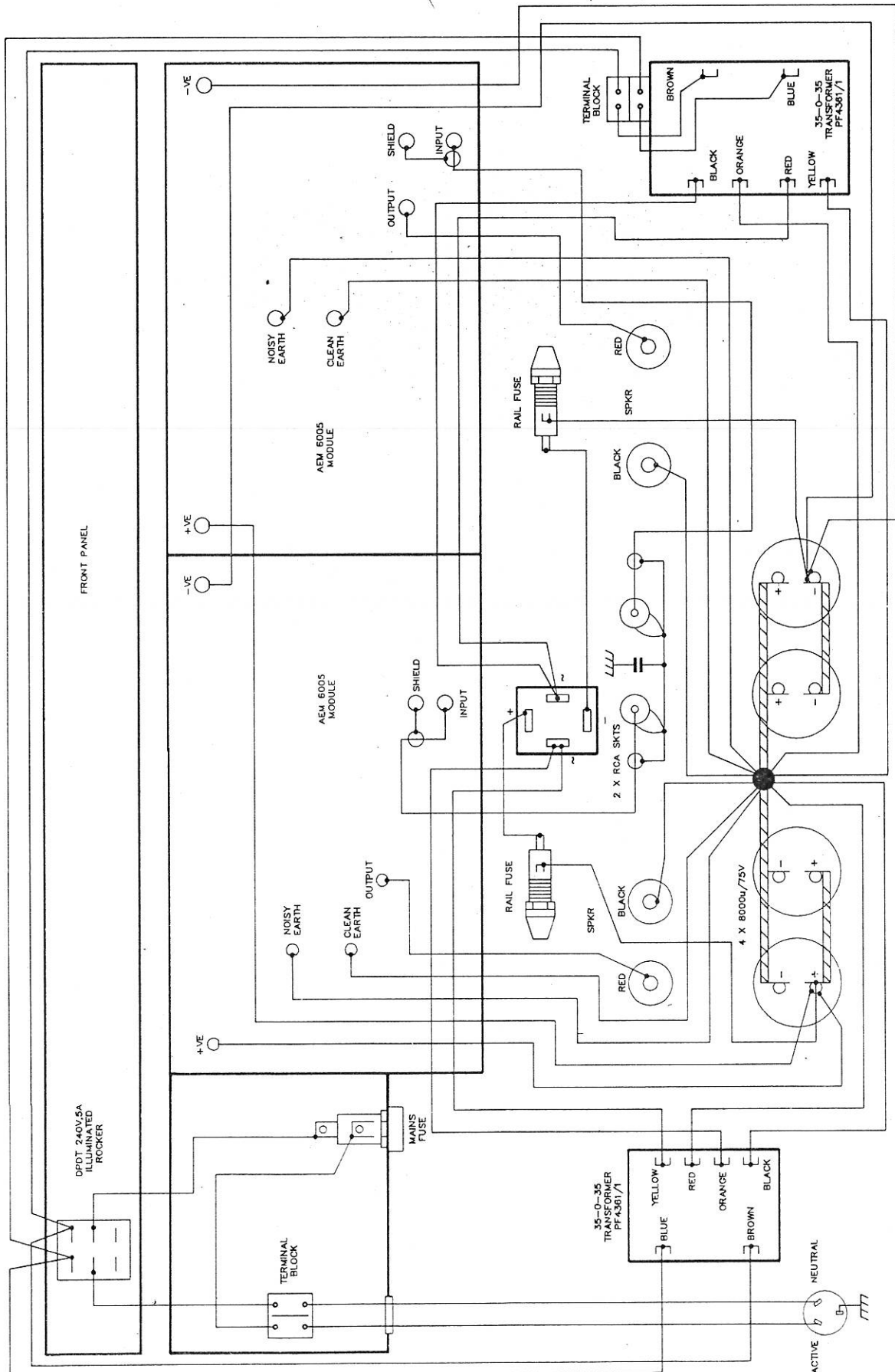

finalising setting of the preset potentiometer as the dc offset tends to drift whilst warming up.

Module mounting and wiring

Once you have completed the mounting of the modules onto the heatsink bracket, you can mount the bracket into the chassis, bolting it on the front panel heatsink. Before doing this, however, be sure to have drilled out the holes on the pc board for the input, output and rail wiring to suit the wire used. The supply rail wires will need to be of substantial size to ensure the best performance and we employed "Monster Cable".

Before actually mounting the modules, it is wise to wire the input into position on the board as this also becomes more difficult after mounting has been completed. Use shielded cable to wire the input as these wires will have to pass fairly close to transformers. Hum is injected into the input wiring simply by its physical proximity to the transformers, so experiment with the location of this wiring if you experience any difficulty with hum. The hum performance of the upgraded unit is extremely good and was achieved with no difficulty.

Once the module has been readied it can be secured to the heatsink, making sure to use a generous amount of thermal paste between the bracket and the front panel heatsink to ensure good thermal contact between them.

The modules should now be securely in position and the rest of the wiring can be completed. One aspect which will need to be looked at, whether you are mounting these modules into your old 5000 or into a completely new chassis, is that of the fusing. The fusing is the last line of defense for your modules in the case of a fault, so it is imperative that the rail fuses not be left out. In the case of the Series 5000 these fuses were incorporated onto the pc board. This has not been done in the AEM6005 module since it can introduce significant resistance in series with the power supply to the MOSFETs which can cause some degradation in overall performance.

The transient performance of a power amp is greatly affected by the capacity of the power supply to deliver current quickly to the output devices. It is for this reason that heavy gauge cables are specified for the rail and output connections. Incorporation of supply fuses into the supply line introduces both resistance and inductance which is not desirable. Instead, fuses are fitted between the output of the bridge rectifier and the main filter capacitors. As seen in the parts list, we recommend the use of 3AG 5A slow blow fuses. The slow blow types are necessary because of the surge current that occurs at the moment of turn on due to the charging of the

Underside view inside the unit. Note the two power supply fuse holders either side of the bridge rectifier which is mounted on an aluminium plate running between the two mains transformers. The mains fuse is seen in the enclosure at top right.

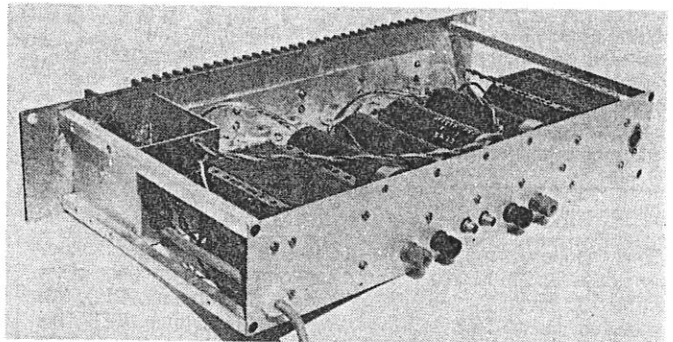
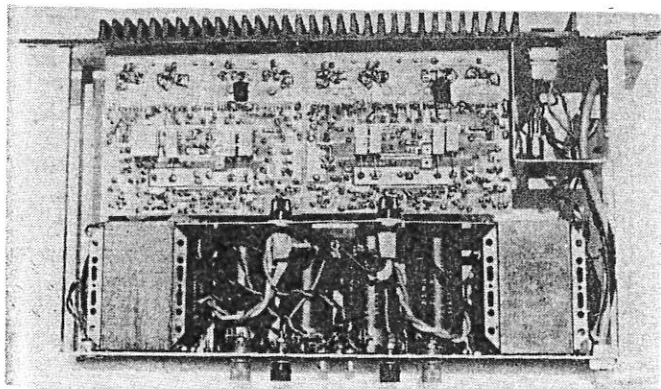

Rear, half-angle view of the unit, showing the connectors mounted on the rear panel. The two input RCA sockets are between the two pairs of speaker terminals, while the DIN socket at upper right provides low voltage ac output for accessories. The mains cord enters via a grommet at bottom left.

main electrolytic capacitors. At the instant of turn on these capacitors represent a short circuit and the resulting huge current surge will blow normal 5 A fuses. The slow blow type will not blow unless the excessive amount of current continues. In the prototype unit these fuses are mounted with 3AG fuse holders which are mounted to the bracket within the 5000 chassis used to secure the bridge rectifier.

Once the fusing is complete you should wire the earth and rail wires. It is essential to ensure that the rails are wired correctly. Check the filter capacitors to see which is the positive, negative and earth and connect these points to their respective positions on the modules according to the component overlay published in Part 1. The earthing arrangement for the 6005 module is just as imperative as it was for the 6000 power amp modules. There are two earth areas on the pc board which need to be connected to the centre point of the filter capacitors. This is to ensure that the clean signal earth is clearly separated from the noisy power supply earth. If this is not done the module will still operate, although with hum and noise figures orders of magnitude worse than those published. The output should be wired directly from the pc board with the black output terminal connected directly to the centre point of the main electrolytic filter capacitors.

If you are upgrading the Series 5000 the same power supply can be used with the exception of the changes to the power supply fusing which has already been discussed. We have ▶

AEM6005 PARTS LIST

- 2 x AEM6005 modules;
- 1 x heatsink bracket;
- 1 x Series 5000 heatsink and chassis;
- 4 x 8000u/75 V electrolytics;
- 2 x PF4361/1 transformers;
- 1 x 100n/630 V metallised film capacitor.
- 1 x 240 Vac DPDT illuminated rocker switch;
- 2 x red binding posts;
- 2 x black binding posts;
- 4 x earth lugs;
- 2 x RCA sockets;
- 1 x PB40 bridge rectifier;
- 2 x 5A 3AG slow blow fuses;
- 3 x 3AG chassis-mount fuse holders;
- 2 x 2-way terminal blocks;
- Two metres of heavy gauge hookup wire of at least 32 x 0.2 mm, or "Monster Cable", for power supply wiring;
- Mains cable, plug and clamp grommet.

aem project 6005

Drilling details for the heatsink bracket. Mounting hole positions shown in the upright piece were taken from the original 5000 heatsink which located the mounting bolts between the fins. Later heatsink designs have tapped holes positioned behind the fins which necessitate slightly different hole positions. These should be measured from your unit.

NOTE: SUBSTITUTE DUAL JFET INPUT DEVICES

Some incompatibilities between various input stage devices employed for Q1-Q2 have become apparent since publication of the AEM6000 module (June, July, August September 1986). We specified the NTE461, a New Tone Electronics dual JFET. This device is important to the overall performance of the 6000 and 6005 modules. Some suppliers have substituted alternative devices which some constructors have raised questions about.

The Philips BFQ10 can be used in the circuit instead of the NTE device without any difficulties. The 2SK146 dual JFET will operate in the circuit but has a different pinout and is therefore difficult to mount. We understand that the NTE device is available from Stewart Electronics in Melbourne. The pinout of all these devices, NTE461, Philips BFQ10, and the 2SK146 have been shown elsewhere in this article to clear all such confusion.

also included a diagram for a dual mono power supply for those wishing to employ it. This power supply can be incorporated within the 5000 chassis with the addition of a second bridge rectifier. The 5000 power supply is a single supply which is used for both modules. The dual mono configuration enables the power amp to become two mono power amps in the same box which is said to have superior channel separation compared to the mono supply.

To wire up the dual mono supply, follow the circuit diagram closely to ensure correctness. We have decided not to include drilling details of a new chassis and leave it to the enthusiast who may wish to experiment. Be careful to check the orientation of your electrolytics and bridge rectifiers when following the circuit diagram, along with the wiring of the transformers, as damage will occur if these are incorrect.

Pay particular attention to all of the 240 volt wiring. Ensure that all terminations and solder joints have been securely made. It is essential to be aware that any shorts in the 240 V wiring will cause damage.

Hold breath . . . and switch on

With your wiring completed, before powering-up you should recheck the wiring and run through the amplifier with a continuity meter to ensure all is well.

Power-up the amp. If all is well, then leave the amp to warm up. This is necessary to allow time for the amp to stabilize before any adjustments are made. Set your multimeter on dc volts and connect it to the output of each channel in turn to ensure no dc offset has been disturbed before connecting your loudspeaker. If there is a dc offset, then use an insulated screwdriver to adjust the preset RV1. Finally, before connecting the 6005 to your loudspeakers, you should switch the amp on and off a few times to ensure all is well.

LEVEL

We expect that constructors of an

INTERMEDIATE

level, between beginners and experienced persons, should be able to successfully complete this project.

