

*A preview of our new powerful stereo amplifier*

# Playmaster Mosfet Stereo Amplifier

We believe that this new Playmaster stereo amplifier will be the most successful we have published to date. It has virtually all the features of expensive commercial amplifiers and generous power output of 50 watts per channel.

by LEO SIMPSON

Over the last few months one topic has dominated conversation at the offices of "Electronics Australia". It has been the subject of much trial and tribulation. There have been heated discussions, impassioned pleas on one aspect or another. The topic of all this animated discussion has not been inflation or elections or computers. No, the topic has been our new Playmaster Mosfet Stereo Amplifier.

Part of the reason for this all-consuming interest by the "Electronics Australia" staff in the new amplifier is that at least five of those staff members were actually involved in the design, construction and presentation of the project while all the others had a worthwhile contribution in the form of ideas, suggestions and reactions. So this amplifier is very much a team project.

The fact that the new amplifier is the result of a team effort is partly due to necessity. A project such as this could

take a much longer time to develop if it was the sole effort of one man. And partly it was due to particular interest by each member of the "Electronics Australia" staff.

We were conscious that we had a very hard act to follow in the form of the highly successful Playmaster Twin Twenty-Five and Playmaster Forty-Forty stereo amplifiers presented back in 1976. These amplifiers were successful because they were easy to build and set up and they were very reliable. Apart from that, they gave a high order of performance at a fraction of the price of an equivalent commercial amplifier.

So we were conscious of the fact that our new amplifier would have to equal or better the Twin Twenty-Five and Forty-Forty series. In that respect, we were helped by the fact that Mosfet power transistors have now become readily available at reasonable prices. This gives our amplifier an advantage

over most commercial amplifiers because only a few very expensive amplifiers on the market employ these devices.

Our new amplifier has a relatively large and impressive front panel with anodised scratch-grain finish together with a fine array of imported knobs. In this respect, it will match the well-finished exterior of typical commercial amplifiers. Where it beats many commercial amplifiers is in its single-PCB design with a minimum of wiring and good accessibility should service be required in the future.

That is another point in favour of the new Playmaster amplifier in comparison with many commercial amplifiers.

Whereas, all the parts for the present Playmaster series and our new amplifier can be readily purchased over the counter, virtually anywhere in Australia, just try and do the same with any of the semiconductors in a typical commercial amplifier. If you wish to be able to service your amplifier in the future, rather than ship it to a national distributor's service centre at great cost, then the Playmaster is the one to go for. To be fair, the Playmaster will not have a 12-month warranty after you put it together. But you cannot have everything.

Let us now discuss the features and

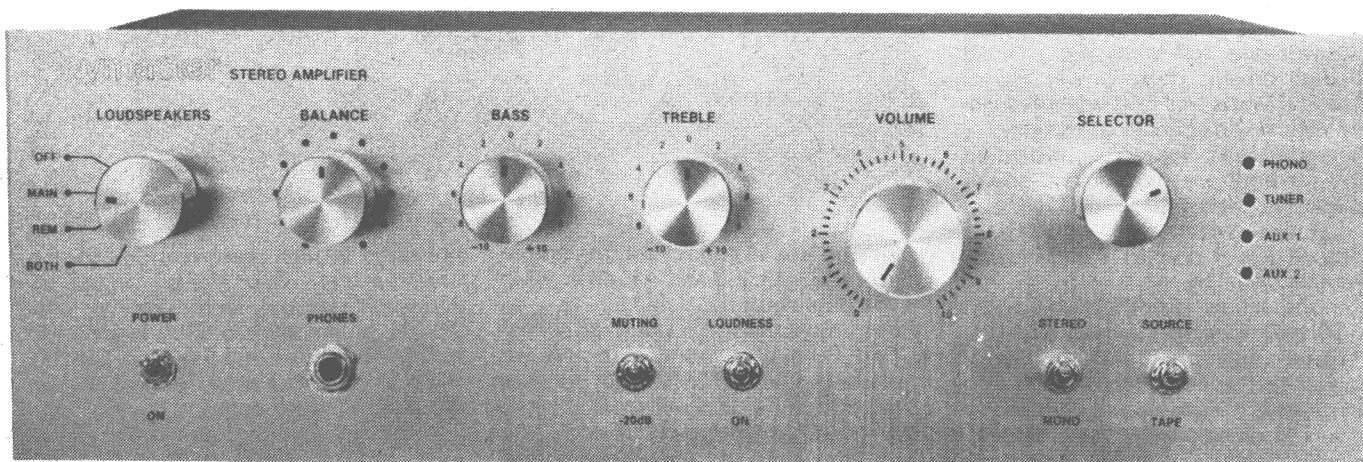

*Our new Playmaster Mosfet stereo amplifier has all the control features of the successful Playmaster 40/40 plus Loudness control, 20dB Muting, switching for two pairs of loudspeakers and source indicator lights.*

facilities of the new amplifier and then we can proceed to talk about the circuit.

The front panel has been designed with the controls in a conventional and logical layout. In common with most other amplifiers, the volume control is the most prominent knob, for easy recognition.

Some of the front panel features are new to Playmaster amplifiers. They include muting, loudspeaker switching and a loudness control. What A "loudness" control? Has "Electronics Australia" finally sold out and given up all its high principles? Has it been taken over by a multinational? Has the Technical Editor had a frontal lobotomy?

No, none of these events have transpired. We have actually bowed to pressure from the many readers who have written in the past complaining that the Playmaster Twin Twenty-Five and Forty-Forty did not have a loudness control. We were anticipating a repetition of this with the present amplifier and so we "went to water" before the event.

Actually, this allows the writer to sit comfortably on the fence. On the one hand, he can say that the design caters for the requirements of constructors and on the other, he can state that anyone who actually uses the loudness facility is a Philistine. What's that you say? You like using the loudness control? You poor demented soul.

Reference to the block diagram for the complete amplifier will show how the facilities are provided. Any of four stereo sources can be selected by the two-pole switch S1. Signals from a magnetic cartridge (phono) are first fed to an RIAA equalisation preamplifier before going to the selector switch S1.

Output signals from the Selector switch, S1, are fed to the "Tape Rec." terminals for connection to any tape recorder or cassette deck. At the same time, the signals are fed to the "Tape Monitor" switch S2, which gives the user a listening choice between the signal from the Selector switch or the playback signals from the tape deck. The Tape Monitor switch also allows simultaneous monitoring of the signal being recorded when a three-head tape deck is employed.

From the Tape Monitor switch, S2, signals are fed via 4.7kΩ resistors to the Stereo/mono switch, S3 and the 50kΩ ganged volume control. The 4.7kΩ resistors are inserted in the signal line to prevent distortion due to the heavy loading effects of one channel on the other if they are merely shorted together to produce the mono mode. To explain this further, consider the RIAA preamplifier which has a very low output impedance due to the considerable negative feedback in the circuit.

Now if there is an output signal from the left preamplifier and a completely dissimilar or no output signal from the right channel preamplifier, the right channel preamplifier will heavily load

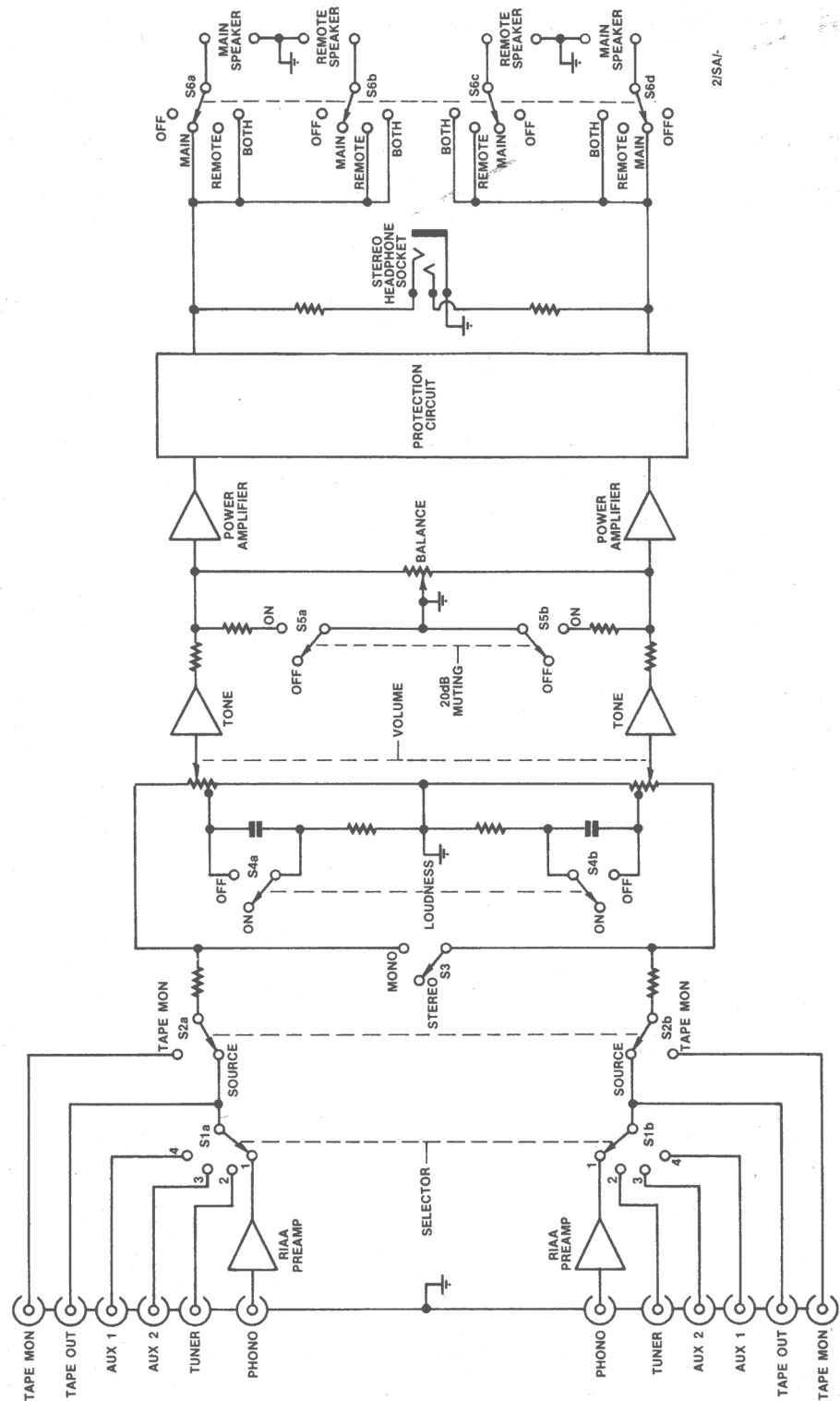

This diagram illustrates the facilities offered by our new stereo amplifier. The protection circuit also provides turn-on and turn-off muting.

the output from the left preamplifier if the two outputs are merely shorted together by the stereo/mono switch. This is because the left preamplifier "sees" a heavy load presented by the very low output impedance of the right channel preamplifier. But matching a low impedance to another low impedance is not the problem — the preamplifier just cannot deliver the heavy currents which would otherwise flow. With the 4.7kΩ

resistors in circuit, each preamplifier (or any other source selected by S1) "sees" a minimum load of approximately 10kΩ when S3 is switched to provide the mono mode.

So far then, the input facilities are no different from those on most other commercial stereo amplifiers with the exception that the stereo/mono switch is often omitted on less expensive models. We have included it for a number of reasons:

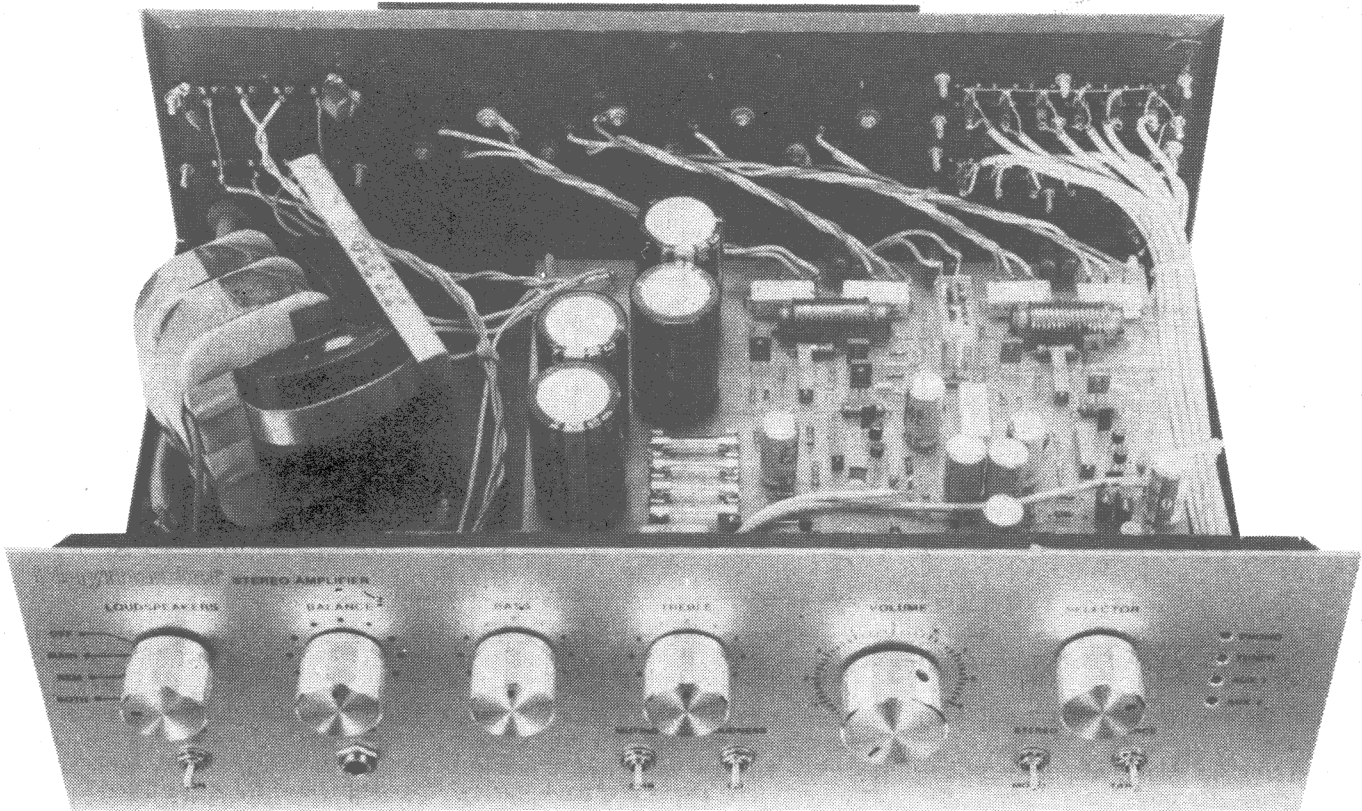

A single large PC board accommodates all the circuitry, including the loudspeaker protection and muting circuit.

It enables a mono signal to be reproduced in both channels, and also enables a noisy stereo program to be reproduced in mono which results in cancellation of the "difference" noise components. As well it enables a quick listening check for correct phase of the loudspeakers — if correct, a mono signal will appear to come from a point midway between the two loudspeakers.

Following the stereo/mono switch is the ganged volume control for both channels of the amplifier. Thus the high level signals (100mV or more) must pass via the volume control before they are fed to the active tone control stages. This ensures that the tone controls are never overloaded (unless of course the following power amplifier stages are grossly overloaded).

The volume control is tapped at 40% of rotation to provide that (controversial) loudness facility. This feature is no more valid than the loudness controls on any other amplifier but it should make some readers happy. It provides bass boost but no treble boost.

Output signals from the tone control stages are fed to the balance control and thence to the power amplifiers via 4.7k $\Omega$  resistors. These resistors combine with the balance control to provide smooth control action and at the same time, en-

sure that neither of the tone control stages is unduly loaded when the balance control is rotated to either extreme. Without the 4.7k $\Omega$  resistors the output of the tone controls could be completely shorted when the balance control was rotated to one extreme.

Associated with the balance control and its just-mentioned 4.7k $\Omega$  resistors is the two-pole muting switch S5. This provides a signal reduction of 20dB by means of additional resistors shunted across the balance control. The muting feature is handy for temporary interrup-

tions to your listening such as telephone conversations. It is also useful for background listening where very low settings of the volume control may cause one channel to be cut off.

Following the power amplifiers is the loudspeaker protection circuit which disconnects the load if an amplifier fault imposes DC voltage on the output. This circuit also provides a delayed turn-on feature to prevent the loudspeakers giving a "thump" at switch-on. While this feature can be optional, we regard it as highly desirable as loudspeakers are

TADIRAN

# The Fail-Safe 10-Yr Lithium Batteries

BY TADIRAN ISRAEL ELECTRONICS

Power CMOS with single cell.  
Nominal Voltage 3.4V per cell.

**TECNICO ELECTRONICS**

P.O. Box 50, Lane Cove, N.S.W. 2066, Tel. (02) 427 3444  
P.O. Box 520, Clayton, Vic. 3168, Tel. (03) 544 7833



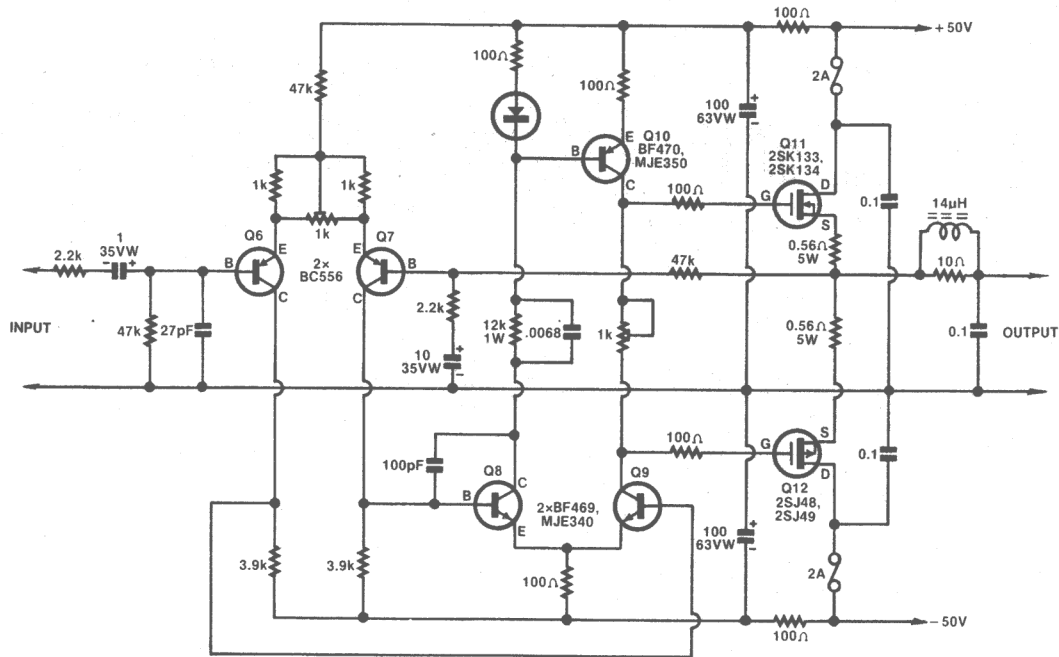

With a complement of just seven transistors and one diode, the power amplifier circuit can deliver in excess of 50 watts RMS.

usually far more expensive to repair than amplifiers.

If an amplifier with loudspeaker protection does become faulty, only the amplifier will need to be repaired. If the amplifier does not have protection for the loudspeakers, the total repair bill for loudspeakers and amplifier can be much more expensive. In our opinion, all amplifiers capable of more than about 20 watts or so, per channel, and having direct-coupling to the output, should have loudspeaker protection.

Following the loudspeaker protection circuitry is the four-pole loudspeaker switch S6, which gives a choice of one or both of two pairs of loudspeakers or switching the loudspeakers off. The headphone drive is not affected by this switch.

On the rear panel all small signal con-

nections are made via RCA sockets. These are compatible with the connecting leads supplied with most turntables, tuners and tape decks and have the advantage that they are easier to wire than DIN sockets. Nor is there any problem with wiring convention as there is with DIN sockets.

Loudspeaker connections are made via spring-loaded or screw terminals which have the advantage that connections are easily made without the necessity for soldered plugs.

Also mounted on the rear panel is a large single-sided heatsink which accommodates the four Mosfet power transistors.

That leads us to the next topic in this article – a discussion on the pros and cons of power Mosfets.

To read some of the promotional infor-

mation on power Mosfets, it is quite easy to gain the impression that they are the answer to an amplifier designer's prayer. Some of the advantages listed for power Mosfets are as follows:

- (1) They require a very low driving power as they are voltage-controlled devices.
- (2) Good frequency response and high switching speed due to absence of carrier storage effect.
- (3) Free from current concentration, so no Second-Breakdown.
- (4) Negative temperature coefficients so no thermal runaway
- (5) High input impedance and high gain.

Taken separately, all these characteristics are present in power Mosfets. But, as we shall see, that "ain't the whole story", not by a long shot. When you want all those characteristics together the rainbow begins to fade away.

Let us have a look at the first two characteristics and see how they work out in practice. Yes, it is true that Mosfets are potentially capable of excellent high frequency response, especially when used as source followers. However, this is only true if the Mosfet is driven from a low source impedance, ie, a voltage source. As soon as the source impedance becomes appreciable, say 1kΩ or more, the Mosfet source follower is not much better than a typical bipolar power transistor such as the common "garden-variety" 2N3055 (when driven from a voltage source in the same mode).

The reason for this effective loss of high frequency response is the very high input capacitance of typical power Mosfets.

**NOW! The Cordless MICROPHONE/ TRANSMITTER**

**ONLY \$14.50**  
Post Paid  
Anywhere  
in Australia

To: **Oatley Electronics**  
**PO Box 89, OATLEY, NSW 2223.**

Enclosed is cheque or Money Order for \$14.50 for the Cordless Microphone/Transmitter.

NAME .....

ADDRESS .....

Postcode .....

May be received on any FM Radio Band. Range: Approx 100 metres. Two penlight batteries power it for several hundred hours. Turn your FM Radio into a PA System. Only 10cm long.

## PLAYMASTER STEREO AMPLIFIER

This is typically 400pF or more for the devices used here. So, the ability of the Mosfet to function as a voltage controlled device is not a virtue but a necessity, if high frequency response is to be obtained.

And if a voltage source is required (ie, low source impedance) then the advantage of high input impedance is lost. In fact, to judge from a number of commercial amplifier designs we have seen, the only really effective way of obtaining wide bandwidth (ie, up to several Megahertz or more) from a power Mosfet output stage is to drive it with emitter-followers. But to do that largely negates the fourth advantage listed above; no thermal runaway.

Used in a class-B output stage by themselves, power Mosfets exhibit a negative temperature coefficient of drain current versus gate voltage, provided the drain current is around 100 milliamps or more, for the particular devices used in our circuit. This means that the familiar "Vbe multiplier" transistor which provides quiescent current stabilisation in typical bipolar amplifiers can be dispensed with. But if complementary emitter-followers are used to drive the Mosfet output stage, the Vbe multiplier must be incorporated.

Another disadvantage of the use of emitter-followers is that it can make the amplifier harder to stabilise because the emitter-followers insert another "pole" in the open-loop characteristic. Put another way, this means that the emitter-followers have their own frequency rolloff characteristic which is added to the rolloffs due to other stages in the amplifier.

Power Mosfets are also prone to oscillate parasitically in high-gain amplifiers and the most effective cure for this is to add "stopper" resistors of several hundred ohms in series with the gate electrodes. This cures the oscillation problem (usually) but also reduces the gain-bandwidth product, as explained above.

Perhaps the major advantage of power Mosfets is their freedom from second-breakdown effects. This means that there is no need to derate the device when operating at high voltage, as is the case with all bipolar transistors. This means that a given pair of 100W Mosfets can be used to provide a higher rated amplifier which would be more tolerant of variations in load impedance and phase angle, than would be the case with equivalent bipolar transistors.

One other aspect should be mentioned, that of junction temperature. The maximum junction temperature of the Mosfets used here is 150 degrees Celsius while typical bipolar power transistors have a junction temperature rating of 200 degrees Celsius. While this would

seem to limit the Mosfet unduly, the fact that they tend to "shut down" at high temperatures means that they are inherently self-protecting which is definitely an advantage.

Now let us discuss the power amplifiers which are based on a circuit provided in application literature published by Hitachi Semiconductors, Japan. Hitachi Mosfets are distributed in Australia by Plessey Components, Christina Road, Villawood, NSW and they will be available at a number of major kit suppliers.

We were unable to use the Hitachi circuit in its original form, for two reasons. The first was that it depends on rather special driver transistors which are unavailable in Australia and second, we could not make it work in a practical layout — it oscillated furiously at very high frequencies. So we have produced a modified version which is unconditionally stable while still giving creditably low distortion and lots of power. There are, undoubtedly, other more complicated circuits giving lower distortion but a simple circuit is generally more reliable and trouble-free.

Now refer to the circuit diagram of the power amplifier. The input stage is a differential amplifier employing two high voltage PNP transistors, Q6 and Q7. This drives another differential pair, using NPN transistors Q8 and Q9 together with current mirror Q10. This class-A driver stage then feeds the output power Mosfets via 100Ω stopper resistors.

Quiescent current is set in the output stage by the variable 1kΩ trimpot connected between the collectors of Q9 and Q10.

Voltage gain of the power amplifier is set by the ratio of the 47kΩ and 2.2kΩ resistors at the base of Q7. The lower cutoff frequency is set by the 10μF capacitor in series with the 2.2kΩ resistor. This capacitor also sets the DC feedback at 100% which means that the DC gain is unity.

Output offset voltage adjustment is provided by the 1kΩ trimpot between the emitters of Q6 and Q7. This allows the output offset voltage to be set to less than ±1mV. Without this circuit feature, the offset voltage could be expected to be typically around ±50mV or less. While ideally the offset voltage should be as close as possible to zero, the main reason for incorporating offset adjustment in our circuit is make the relay protection circuit silent; if there is appreciable offset voltage, the relay will produce an audible "click" from the loudspeaker when it switches on and off.

Source degeneration via the 0.47Ω resistors is provided in the output stage. This reduces the high frequency rolloff which would otherwise occur due to the high input capacitance of the Mosfets. It also allows a reduction in the optimum

quiescent current for thermal stability which means that there is less power dissipation under "no-signal" conditions. Translated, this means the output Fets run cooler.

Single-pole lag compensation is applied from the collector to the base of Q8 via a 100pF capacitor. This renders the amplifier stable with overall feedback applied.

A final refinement is the RLC network in the output circuit. This is based on a paper by A. N. Thiele and published in the September 1975 issue of "Proceedings of the IREE". This, and other measures, renders the amplifier unconditionally stable. There is a proviso here, in that short circuits or very large capacitive loads will cause the fuses to blow. (To be continued)

Telecommunications Division

### COURSES IN TELECOMMUNICATIONS

at

RMIT TECHNICAL COLLEGE

The Telecommunications Division conducts Full-time and Part-time (Day & Evening) courses at Electronics Mechanic and Electronics Technician level in the following areas:—

**Communications —**  
Radio and Broadcasting

**Digital Electronics —**  
Microprocessors,  
Minicomputer Servicing

**Industrial Electronics —**  
Electronic Control Systems

**Television —**  
Colour TV Servicing, TV Studios

**Other Courses** offered by this Division include 35 mm and 16 mm Motion Picture Projection, Post-trade and Post-technician subjects, Advanced Audio, Video Tape Recorders, TV Antennae, Remote Controlled TV, etc.

**Applications** close on 16 January

**Further Information** is available from the Telecommunications Division, Telephone 341 2358.

RMIT Technical College, 80 Victoria Street, Carlton 3052. Telephone 347 7611.

**RMIT**  
THE DOOR TO  
GREATER  
OPPORTUNITY  
SINCE 1887

4890